

520kHz/1.6MHz – Space-Efficient Boost and SEPIC DC-DC Regulator

General Description

The LM2735 is an easy-to-use, space-efficient 2.1A low-side switch regulator ideal for Boost and SEPIC DC-DC regulation. It provides all the active functions to provide local DC/DC conversion with fast-transient response and accurate regulation in the smallest PCB area. Switching frequency is internally set to either 520kHz or 1.6MHz, allowing the use of extremely small surface mount inductor and chip capacitors while providing efficiencies up to 90%. Current-mode control and internal compensation provide ease-of-use, minimal component count, and high-performance regulation over a wide range of operating conditions. External shutdown features an ultra-low standby current of 80 nA ideal for portable applications. Tiny SOT23-5, LLP-6, and eMSOP-8 packages provide space-savings. Additional features include internal soft-start, circuitry to reduce inrush current, pulse-by-pulse current limit, and thermal shutdown.

Features

- Input voltage range 2.7V to 5.5V
- Output voltage range 3V to 24V
- 2.1A switch current over full temperature range
- Current-Mode control
- Logic high enable pin
- Ultra low standby current of 80 nA in shutdown
- 170 mΩ NMOS switch
- $\pm 2\%$ feedback voltage accuracy
- Ease-of-use, small total solution size
 - Internal soft-start
 - Internal compensation
 - Two switching frequencies
 - 520 kHz (LM2735-Y)
 - 1.6 MHz (LM2735-X)
 - Uses small surface mount inductors and chip capacitors
 - Tiny SOT23-5, LLP-6, and eMSOP-8 packages
- LM2735Q is AEC-Q100 Grade 1 qualified and is manufactured on an Automotive Grade Flow

Applications

- LCD Display Backlighting For Portable Applications
- OLED Panel Power Supply
- USB Powered Devices
- Digital Still and Video Cameras
- White LED Current Source
- Automotive

Typical Boost Application Circuit

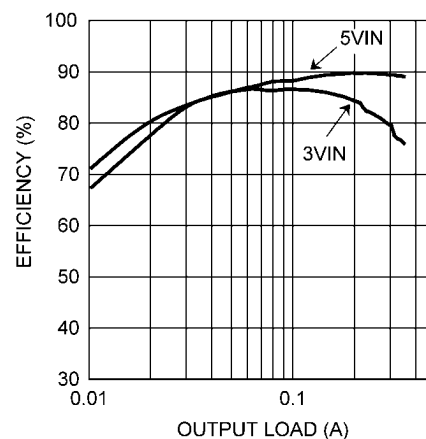
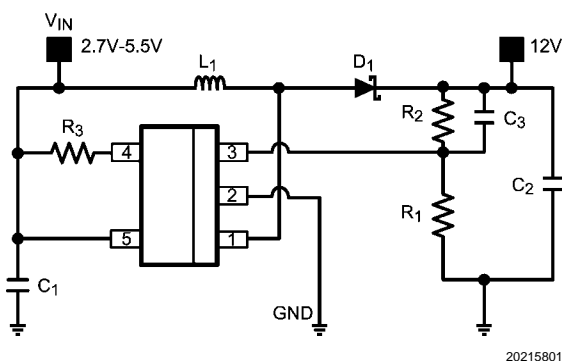

Efficiency vs Load Current $V_O = 12V$

Connection Diagrams

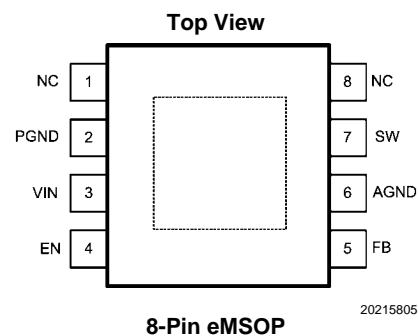
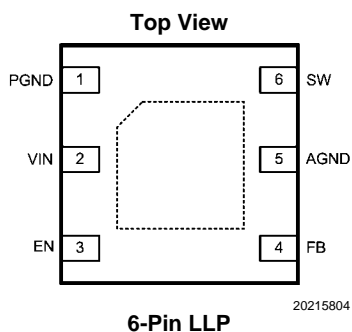
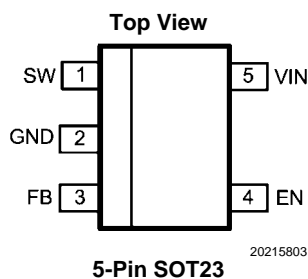

Ordering Information

Order Number	Description	Package Type	Package Drawing	Supplied As	Features	
LM2735YMF	520kHz	SOT23-5	MF05A	1000 units tape & reel	AEC-Q100 Grade 1 qualified. Automotive Grade Production Flow*	
LM2735YMF				3000 units tape & reel		
LM2735YQMF				1000 units tape & reel		
LM2735YQMF				3000 units tape & reel		
LM2735YSD		LLP-6	SDE06A	1000 units tape & reel		
LM2735YSDX				4500 units tape & reel		
LM2735YQSD				1000 units tape & reel		
LM2735YQSDX				4500 units tape & reel		
LM2735YMY		eMSOP-8	MUY08A	1000 units tape & reel		
LM2735YMYX				3500 units tape & reel		
LM2735XMF		1.6MHz	SOT23-5	MF05A	1000 units tape & reel	AEC-Q100 Grade 1 qualified. Automotive Grade Production Flow*
LM2735XMF					3000 units tape & reel	
LM2735XQMF	1000 units tape & reel					
LM2735XQMF	3000 units tape & reel					
LM2735XSD	LLP-6		SDE06A	1000 units tape & reel		
LM2735XSDX				4500 units tape & reel		
LM2735XMY				1000 units tape & reel		
LM2735XMYX				3500 units tape & reel		
LM2735XMY	eMSOP-8		MUY08A	1000 units tape & reel		
LM2735XMYX				3500 units tape & reel		

*Automotive Grade (Q) product incorporates enhanced manufacturing and support processes for the automotive market, including defect detection methodologies. Reliability qualification is compliant with the requirements and temperature grades defined in the AEC-Q100 standard. Automotive grade products are identified with the letter Q. For more information go to <http://www.national.com/automotive>.

Pin Descriptions - 5-Pin SOT23

Pin	Name	Function
1	SW	Output switch. Connect to the inductor, output diode.
2	GND	Signal and power ground pin. Place the bottom resistor of the feedback network as close as possible to this pin.
3	FB	Feedback pin. Connect FB to external resistor divider to set output voltage.
4	EN	Shutdown control input. Logic high enables operation. Do not allow this pin to float or be greater than $V_{IN} + 0.3V$.
5	VIN	Supply voltage for power stage, and input supply voltage.

Pin Descriptions - 6-Pin LLP

Pin	Name	Function
1	PGND	Power ground pin. Place PGND and output capacitor GND close together.
2	VIN	Supply voltage for power stage, and input supply voltage.
3	EN	Shutdown control input. Logic high enables operation. Do not allow this pin to float or be greater than $V_{IN} + 0.3V$.
4	FB	Feedback pin. Connect FB to external resistor divider to set output voltage.
5	AGND	Signal ground pin. Place the bottom resistor of the feedback network as close as possible to this pin & pin 4.
6	SW	Output switch. Connect to the inductor, output diode.
DAP	GND	Signal & Power ground. Connect to pin 1 & pin 5 on top layer. Place 4-6 vias from DAP to bottom layer GND plane.

Pin Descriptions - 8-Pin eMSOP

Pin	Name	Function
1		No Connect
2	PGND	Power ground pin. Place PGND and output capacitor GND close together.
3	VIN	Supply voltage for power stage, and input supply voltage.
4	EN	Shutdown control input. Logic high enables operation. Do not allow this pin to float or be greater than $V_{IN} + 0.3V$.
5	FB	Feedback pin. Connect FB to external resistor divider to set output voltage.
6	AGND	Signal ground pin. Place the bottom resistor of the feedback network as close as possible to this pin & pin 5
7	SW	Output switch. Connect to the inductor, output diode.
8		No Connect
DAP	GND	Signal & Power ground. Connect to pin 2 & pin 6 on top layer. Place 4-6 vias from DAP to bottom layer GND plane.

Absolute Maximum Ratings *(Note 1)*

If Military/Aerospace specified devices are required, please contact the Texas Instruments Sales Office/ Distributors for availability and specifications.

V_{IN}	-0.5V to 7V
SW Voltage	-0.5V to 26.5V
FB Voltage	-0.5V to 3.0V
EN Voltage	-0.5V to 7.0V
ESD Susceptibility <i>(Note 4)</i>	2kV
Junction Temperature <i>(Note 2)</i>	150°C
Storage Temp. Range	-65°C to 150°C
Soldering Information	
Infrared/Convection Reflow (15sec)	220°C

Operating Ratings *(Note 1)*

V_{IN}	2.7V to 5.5V
V_{SW}	3V to 24V
V_{EN} <i>(Note 5)</i>	0V to V_{IN}
Junction Temperature Range	-40°C to +125°C
Power Dissipation (Internal) SOT23-5	400 mW

Electrical Characteristics Limits in standard type are for $T_J = 25^\circ\text{C}$ only; limits in **boldface type** apply over the junction temperature range of ($T_J = -40^\circ\text{C}$ to 125°C). Minimum and Maximum limits are guaranteed through test, design, or statistical correlation. Typical values represent the most likely parametric norm at $T_J = 25^\circ\text{C}$, and are provided for reference purposes only. $V_{IN} = 5\text{V}$ unless otherwise indicated under the Conditions column.

Symbol	Parameter	Conditions	Min	Typ	Max	Units
V_{FB}	Feedback Voltage	$-40^\circ\text{C} \leq \text{to } T_J \leq +125^\circ\text{C}$ (SOT23-5)	1.230	1.255	1.280	V
		$0^\circ\text{C} \leq \text{to } T_J \leq +125^\circ\text{C}$ (SOT23-5)	1.236	1.255	1.274	
		$-40^\circ\text{C} \leq \text{to } T_J \leq +125^\circ\text{C}$ (LLP-6)	1.225	1.255	1.285	
		$-0^\circ\text{C} \leq \text{to } T_J \leq +125^\circ\text{C}$ (LLP-6)	1.229	1.255	1.281	
		$-40^\circ\text{C} \leq \text{to } T_J \leq +125^\circ\text{C}$ (eMSOP-8)	1.220	1.255	1.290	
		$0^\circ\text{C} \leq \text{to } T_J \leq +125^\circ\text{C}$ (eMSOP-8)	1.230	1.255	1.280	
$\Delta V_{FB}/V_{IN}$	Feedback Voltage Line Regulation	$V_{IN} = 2.7\text{V to } 5.5\text{V}$		0.06		%/V
I_{FB}	Feedback Input Bias Current			0.1	1	μA
F_{SW}	Switching Frequency	LM2735-X	1200	1600	2000	kHz
		LM2735-Y	360	520	680	
D_{MAX}	Maximum Duty Cycle	LM2735-X	88	96		%
		LM2735-Y	91	99		
D_{MIN}	Minimum Duty Cycle	LM2735-X		5		%
		LM2735-Y		2		
$R_{DS(ON)}$	Switch On Resistance	SOT23-5 and eMSOP-8		170	330	$\text{m}\Omega$
		LLP-6		190	350	
I_{CL}	Switch Current Limit		2.1	3		A
SS	Soft Start			4		ms
I_Q	Quiescent Current (switching)	LM2735-X		7.0	11	mA
		LM2735-Y		3.4	7	
	Quiescent Current (shutdown)	All Options $V_{EN} = 0\text{V}$		80		nA
UVLO	Undervoltage Lockout	VIN Rising		2.3	2.65	V
		VIN Falling	1.7	1.9		
V_{EN_TH}	Shutdown Threshold Voltage	<i>(Note 5)</i>			0.4	V
	Enable Threshold Voltage	<i>(Note 5)</i>	1.8			

Symbol	Parameter	Conditions	Min	Typ	Max	Units
I_{SW}	Switch Leakage	$V_{SW} = 24V$		1.0		μA
I_{EN}	Enable Pin Current	Sink/Source		100		nA
θ_{JA}	Junction to Ambient 0 LFPM Air Flow (<i>Note 3</i>)	LLP-6 and eMSOP-8 Package		80		$^{\circ}C/W$
		SOT23-5 Package		118		
θ_{JC}	Junction to Case (<i>Note 3</i>)	LLP-6 and eMSOP-8 Package		18		$^{\circ}C/W$
		SOT23-5 Package		60		
T_{SD}	Thermal Shutdown Temperature (<i>Note 2</i>)			160		$^{\circ}C$
	Thermal Shutdown Hysteresis			10		

Note 1: Absolute Maximum Ratings indicate limits beyond which damage to the device may occur. Operating Ratings indicate conditions for which the device is intended to be functional, but specific performance is not guaranteed. For guaranteed specifications and the test conditions, see Electrical Characteristics.

Note 2: Thermal shutdown will occur if the junction temperature exceeds the maximum junction temperature of the device

Note 3: Applies for packages soldered directly onto a 3" x 3" PC board with 2oz. copper on 4 layers in still air.

Note 4: The human body model is a 100 pF capacitor discharged through a 1.5 k Ω resistor into each pin.

Note 5: Do not allow this pin to float or be greater than $V_{IN} + 0.3V$.

Typical Performance Characteristics

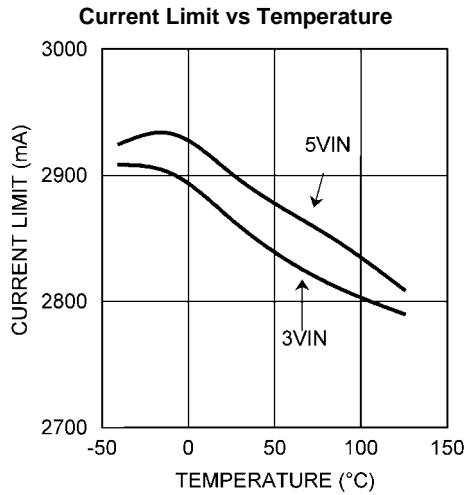

20215806

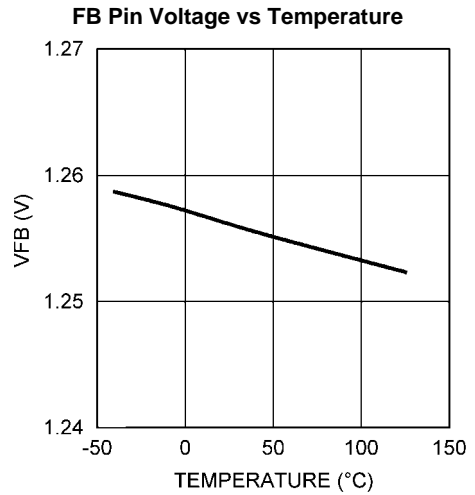

20215807

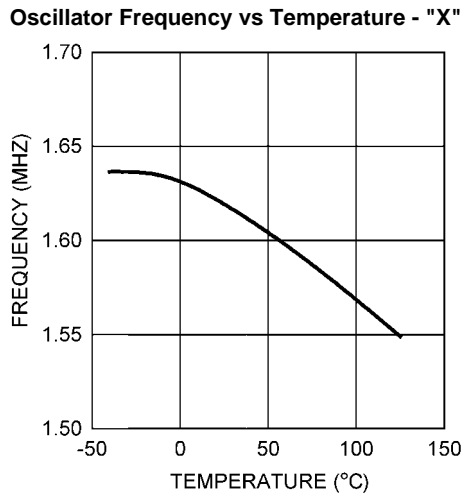

20215808

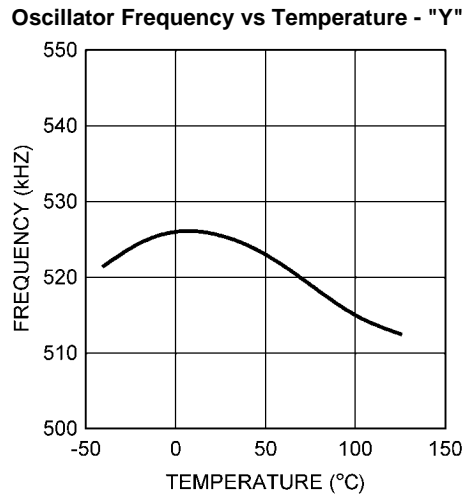

20215809

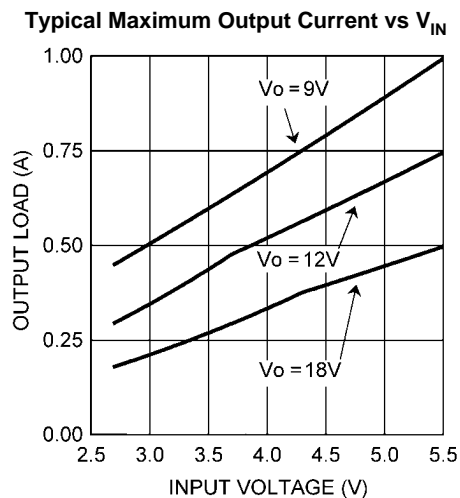

20215810

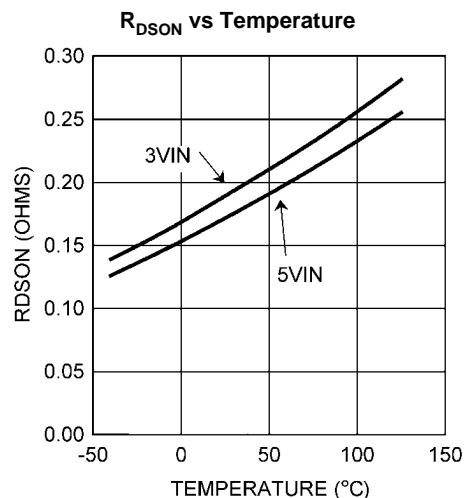

20215811

LM2735X Efficiency vs Load Current, $V_o = 20V$

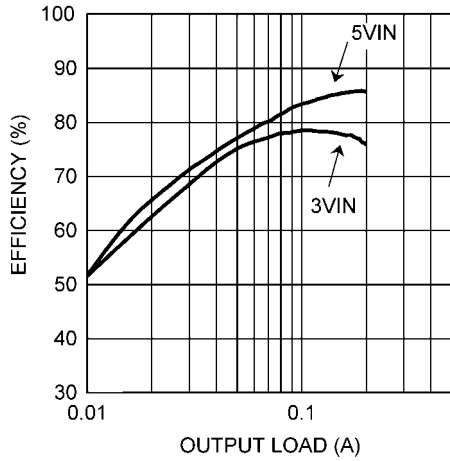

20215812

LM2735Y Efficiency vs Load Current, $V_o = 20V$

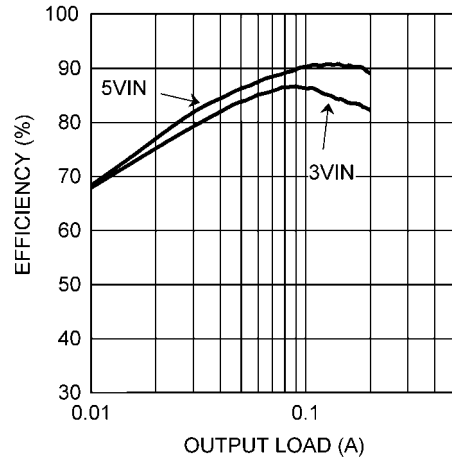

20215813

LM2735X Efficiency vs Load Current, $V_o = 12V$

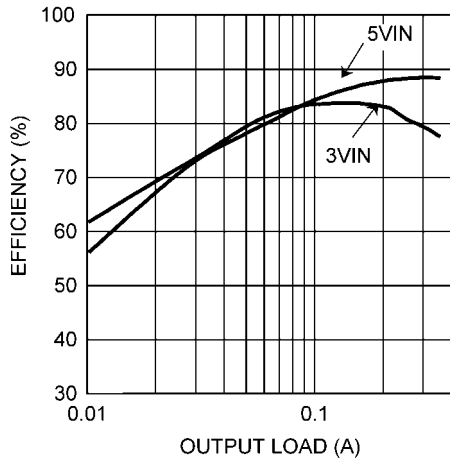

20215814

LM2735Y Efficiency vs Load Current, $V_o = 12V$

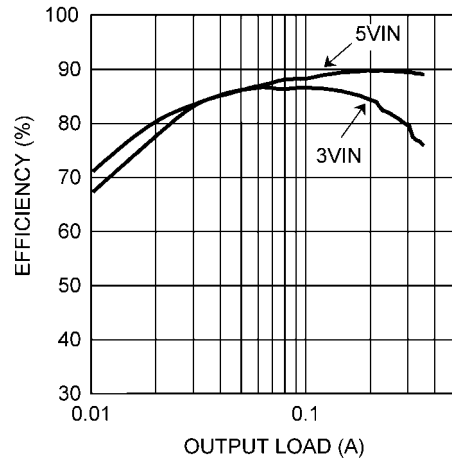

20215815

Output Voltage Load Regulation

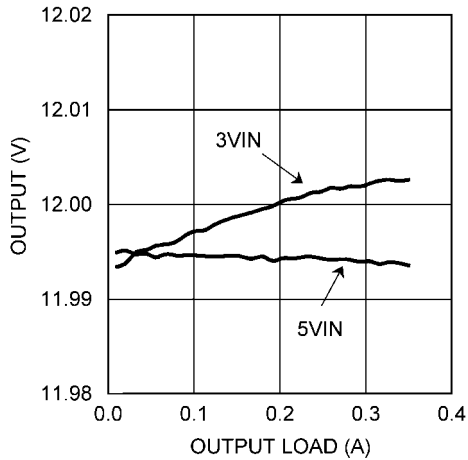

20215816

Output Voltage Line Regulation

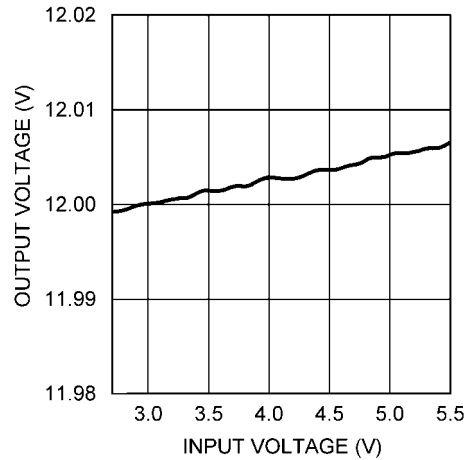

20215817

Simplified Internal Block Diagram

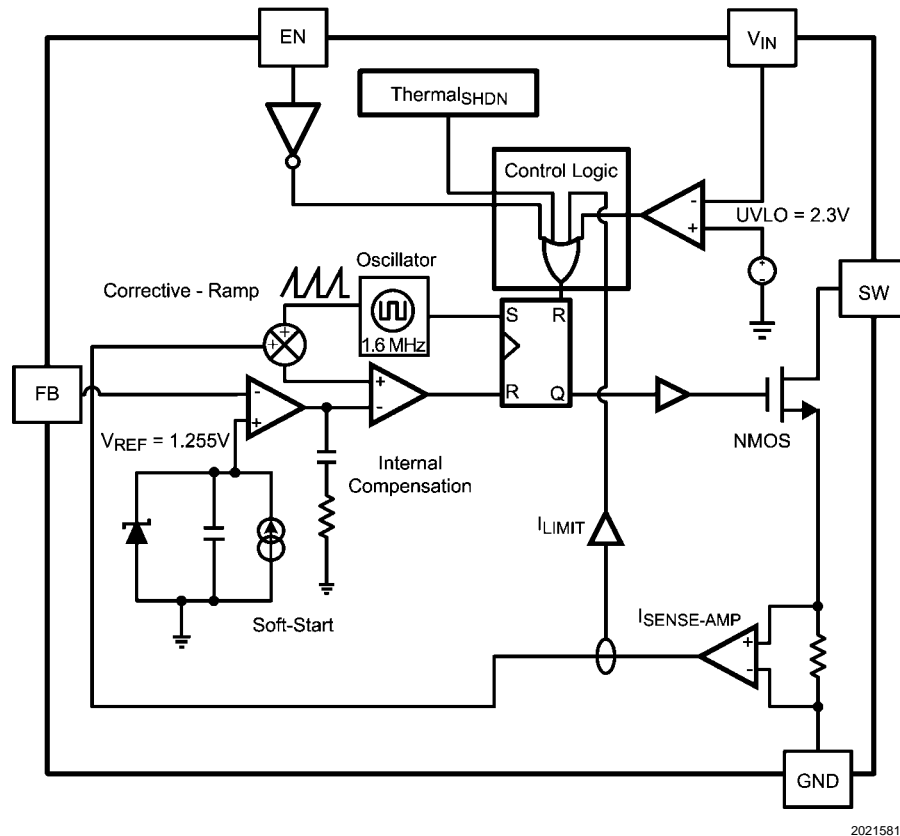

20215818

FIGURE 1. Simplified Block Diagram

Application Information

THEORY OF OPERATION

The LM2735 is a constant frequency PWM boost regulator IC that delivers a minimum of 2.1A peak switch current. The regulator has a preset switching frequency of either 520 kHz or 1.60 MHz. This high frequency allows the LM2735 to operate with small surface mount capacitors and inductors, resulting in a DC/DC converter that requires a minimum amount of board space. The LM2735 is internally compensated, so it is simple to use, and requires few external components. The LM2735 uses current-mode control to regulate the output voltage. The following operating description of the LM2735 will refer to the Simplified Block Diagram (Figure 1) the simplified schematic (Figure 2), and its associated waveforms (Figure 3). The LM2735 supplies a regulated output voltage by switching the internal NMOS control switch at constant frequency and variable duty cycle. A switching cycle begins at the falling edge of the reset pulse generated by the internal oscillator. When this pulse goes low, the output control logic turns on the internal NMOS control switch. During this on-time, the SW pin voltage (V_{SW}) decreases to approximately GND, and the inductor current (I_L) increases with a linear slope. I_L is measured by the current sense amplifier, which generates an output proportional to the switch current. The sensed signal is summed with the regulator's corrective ramp and compared to the error amplifier's output, which is proportional to the difference between the feedback voltage and V_{REF} . When the PWM comparator output goes high, the output switch turns off until the next switching cycle begins. During the switch off-time, inductor current discharges through diode D1, which forces the SW pin to swing to the output voltage plus the forward voltage (V_D) of the diode. The regulator loop adjusts the duty cycle (D) to maintain a constant output voltage .

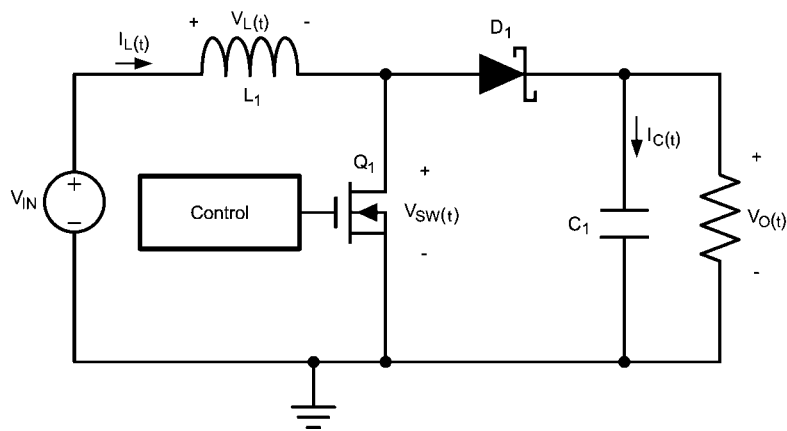

20215819

FIGURE 2. Simplified Schematic

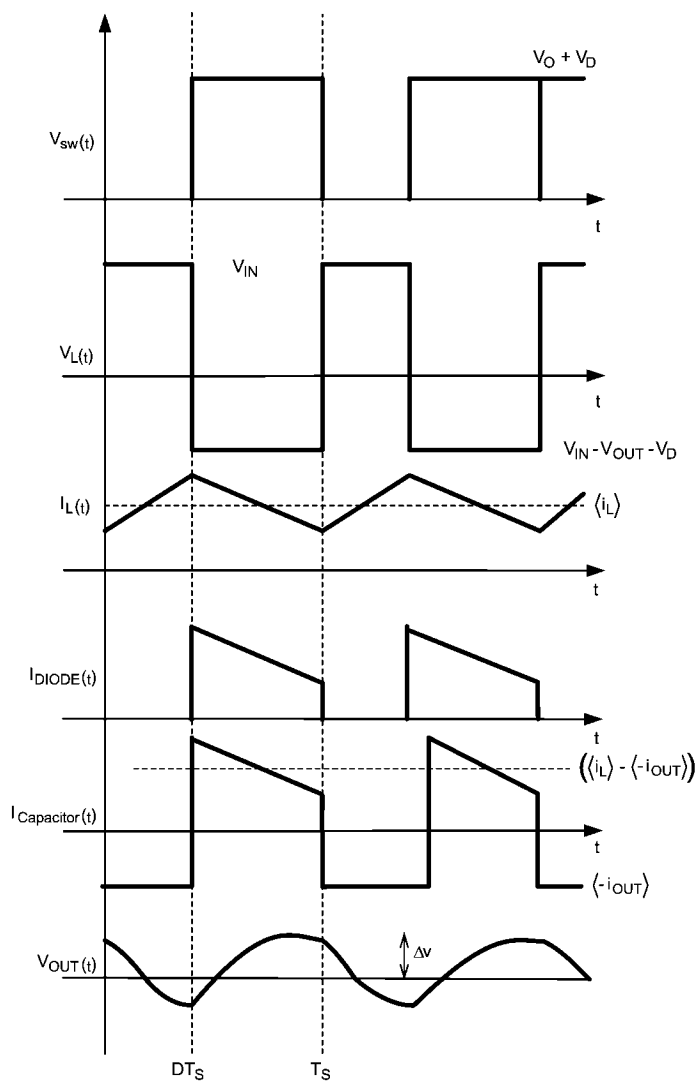

20215820

FIGURE 3. Typical Waveforms

CURRENT LIMIT

The LM2735 uses cycle-by-cycle current limiting to protect the internal NMOS switch. It is important to note that this current limit will not protect the output from excessive current during an output short circuit. The input supply is connected to the output by the series connection of an inductor and a diode. If a short circuit is placed on the output, excessive current can damage both the inductor and diode.

Design Guide

ENABLE PIN / SHUTDOWN MODE

The LM2735 has a shutdown mode that is controlled by the Enable pin (EN). When a logic low voltage is applied to EN, the part is in shutdown mode and its quiescent current drops to typically 80 nA. Switch leakage adds up to another 1 μ A from the input supply. The voltage at this pin should never exceed $V_{IN} + 0.3V$.

THERMAL SHUTDOWN

Thermal shutdown limits total power dissipation by turning off the output switch when the IC junction temperature exceeds 160°C. After thermal shutdown occurs, the output switch doesn't turn on until the junction temperature drops to approximately 150°C.

SOFT-START

This function forces V_{OUT} to increase at a controlled rate during start up. During soft-start, the error amplifier's reference voltage ramps to its nominal value of 1.255V in approximately 4.0ms. This forces the regulator output to ramp up in a more linear and controlled fashion, which helps reduce inrush current.

INDUCTOR SELECTION

The Duty Cycle (D) can be approximated quickly using the ratio of output voltage (V_O) to input voltage (V_{IN}):

$$\frac{V_{OUT}}{V_{IN}} = \left(\frac{1}{1-D} \right) = \frac{1}{D}$$

Therefore:

$$D = \frac{V_{OUT} - V_{IN}}{V_{OUT}}$$

Power losses due to the diode (D1) forward voltage drop, the voltage drop across the internal NMOS switch, the voltage drop across the inductor resistance (R_{DCR}) and switching losses must be included to calculate a more accurate duty cycle (See Calculating Efficiency and Junction Temperature for a detailed explanation). A more accurate formula for calculating the conversion ratio is:

$$\frac{V_{OUT}}{V_{IN}} = \frac{\eta}{D}$$

Where η equals the efficiency of the LM2735 application.

The inductor value determines the input ripple current. Lower inductor values decrease the size of the inductor, but increase the input ripple current. An increase in the inductor value will decrease the input ripple current.

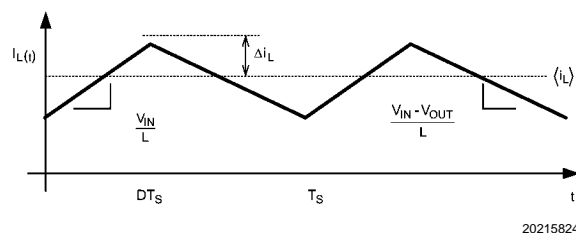

FIGURE 4. Inductor Current

$$\frac{2\Delta i_L}{DT_S} = \left(\frac{V_{IN}}{L} \right)$$

$$\Delta i_L = \left(\frac{V_{IN}}{2L} \right) \times DT_S$$

A good design practice is to design the inductor to produce 10% to 30% ripple of maximum load. From the previous equations, the inductor value is then obtained.

$$L = \left(\frac{V_{IN}}{2 \times \Delta i_L} \right) \times DT_S$$

Where: $1/T_S = F_{SW}$ = switching frequency

One must also ensure that the minimum current limit (2.1A) is not exceeded, so the peak current in the inductor must be calculated. The peak current (I_{LPK}) in the inductor is calculated by:

$$I_{LPK} = I_{IN} + \Delta I_L$$

or

$$I_{LPK} = I_{OUT} / D' + \Delta I_L$$

When selecting an inductor, make sure that it is capable of supporting the peak input current without saturating. Inductor saturation will result in a sudden reduction in inductance and prevent the regulator from operating correctly. Because of the speed of the internal current limit, the peak current of the inductor need only be specified for the required maximum input current. For example, if the designed maximum input current is 1.5A and the peak current is 1.75A, then the inductor should be specified with a saturation current limit of >1.75A. There is no need to specify the saturation or peak current of the inductor at the 3A typical switch current limit.

Because of the operating frequency of the LM2735, ferrite based inductors are preferred to minimize core losses. This presents little restriction since the variety of ferrite-based inductors is huge. Lastly, inductors with lower series resistance (DCR) will provide better operating efficiency. For recommended inductors see Example Circuits.

INPUT CAPACITOR

An input capacitor is necessary to ensure that V_{IN} does not drop excessively during switching transients. The primary specifications of the input capacitor are capacitance, voltage, RMS current rating, and ESL (Equivalent Series Inductance). The recommended input capacitance is 10 μ F to 44 μ F depending on the application. The capacitor manufacturer specifically states the input voltage rating. Make sure to check any recommended deratings and also verify if there is any significant change in capacitance at the operating input voltage and the operating temperature. The ESL of an input capacitor is usually determined by the effective cross sectional area of the current path. At the operating frequencies of the LM2735, certain capacitors may have an ESL so large that the resulting impedance ($2\pi fL$) will be higher than that required to provide stable operation. As a result, surface mount capacitors are strongly recommended. Multilayer ceramic capacitors (MLCC) are good choices for both input and output capacitors and have very low ESL. For MLCCs it is recommended to use X7R or X5R dielectrics. Consult capacitor manufacturer datasheet to see how rated capacitance varies over operating conditions.

OUTPUT CAPACITOR

The LM2735 operates at frequencies allowing the use of ceramic output capacitors without compromising transient response. Ceramic capacitors allow higher inductor ripple without significantly increasing output ripple. The output capacitor is selected based upon the desired output ripple and transient response. The initial current of a load transient is provided mainly by the output capacitor. The output impedance will therefore determine the maximum voltage perturbation. The output ripple of the converter is a function of the capacitor's reactance and its equivalent series resistance (ESR):

$$\Delta V_{OUT} = \Delta I_L \times R_{ESR} + \left(\frac{V_{OUT} \times D}{2 \times F_{SW} \times R_{Load} \times C_{OUT}} \right)$$

When using MLCCs, the ESR is typically so low that the capacitive ripple may dominate. When this occurs, the output ripple will be approximately sinusoidal and 90° phase shifted from the switching action .

Given the availability and quality of MLCCs and the expected output voltage of designs using the LM2735, there is really no need to review any other capacitor technologies. Another benefit of ceramic capacitors is their ability to bypass high frequency noise. A certain amount of switching edge noise will couple through parasitic capacitances in the inductor to the output. A ceramic capacitor will bypass this noise while a tantalum will not. Since the output capacitor is one of the two external components that control the stability of the regulator control loop, most applications will require a minimum at 4.7 μ F of output capacitance. Like the input

capacitor, recommended multilayer ceramic capacitors are X7R or X5R. Again, verify actual capacitance at the desired operating voltage and temperature.

SETTING THE OUTPUT VOLTAGE

The output voltage is set using the following equation where R1 is connected between the FB pin and GND, and R2 is connected between V_{OUT} and the FB pin.

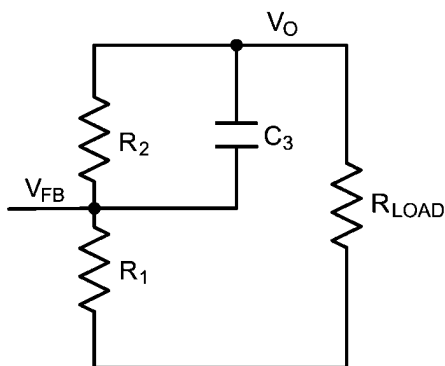

20215829

FIGURE 5. Setting Vout

A good value for R1 is 10kΩ.

$$R_2 = \left(\frac{V_{OUT}}{V_{REF}} - 1 \right) \times R_1$$

COMPENSATION

The LM2735 uses constant frequency peak current mode control. This mode of control allows for a simple external compensation scheme that can be optimized for each application. A complicated mathematical analysis can be completed to fully explain the LM2735's internal & external compensation, but for simplicity, a graphical approach with simple equations will be used. Below is a Gain & Phase plot of a LM2735 that produces a 12V output from a 5V input voltage. The Bode plot shows the total loop Gain & Phase without external compensation.

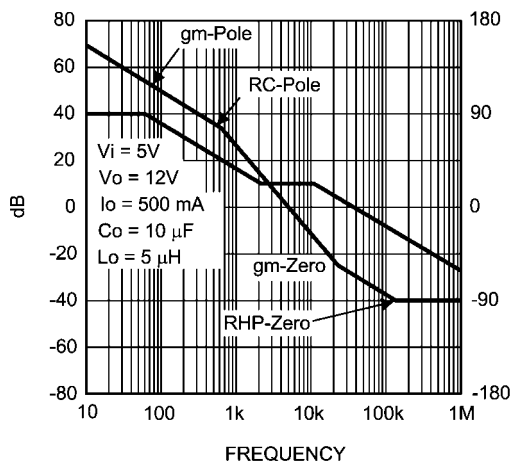

20215831

FIGURE 6. LM2735 Without External Compensation

One can see that the Crossover frequency is fine, but the phase margin at 0dB is very low (22°). A zero can be placed just above the crossover frequency so that the phase margin will be bumped up to a minimum of 45°. Below is the same application with a zero added at 8 kHz.

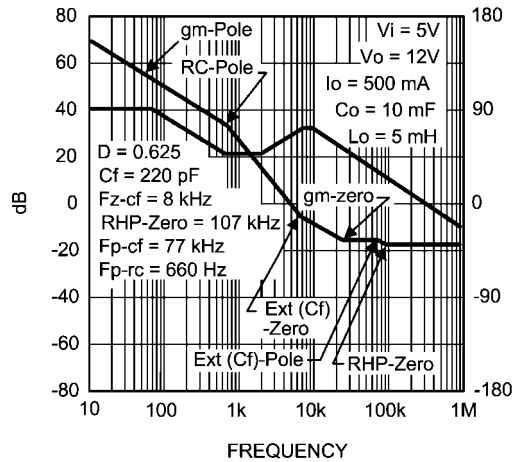

20215832

FIGURE 7. LM2735 With External Compensation

The simplest method to determine the compensation component value is as follows. Set the output voltage with the following equation.

$$R_2 = \left(\frac{V_{OUT}}{V_{REF}} - 1 \right) \times R_1$$

Where R1 is the bottom resistor and R2 is the resistor tied to the output voltage. The next step is to calculate the value of C3. The internal compensation has been designed so that when a zero is added between 5 kHz & 10 kHz the converter will have good transient response with plenty of phase margin for all input & output voltage combinations.

$$F_{ZERO-CF} = \frac{1}{2\pi(R_2 \times C_f)} = 5 \text{ kHz} \rightarrow 10 \text{ kHz}$$

Lower output voltages will have the zero set closer to 10 kHz, and higher output voltages will usually have the zero set closer to 5 kHz. It is always recommended to obtain a Gain/Phase plot for your actual application. One could refer to the Typical applications section to obtain examples of working applications and the associated component values.

Pole @ origin due to internal gm amplifier:

$$F_{P-ORIGIN}$$

Pole due to output load and capacitor:

$$F_{P-RC} = \frac{1}{2\pi(R_{Load} C_{OUT})}$$

This equation only determines the frequency of the pole for perfect current mode control (CMC). I.e, it doesn't take into account the additional internal artificial ramp that is added to the current signal for stability reasons. By adding artificial ramp, you begin to move away from CMC to voltage mode control (VMC). The artifact is that the pole due to the output load and output capacitor will actually be slightly higher in frequency than calculated. In this example it is calculated at 650 Hz, but in reality it is around 1 kHz.

The zero created with capacitor C3 & resistor R2:

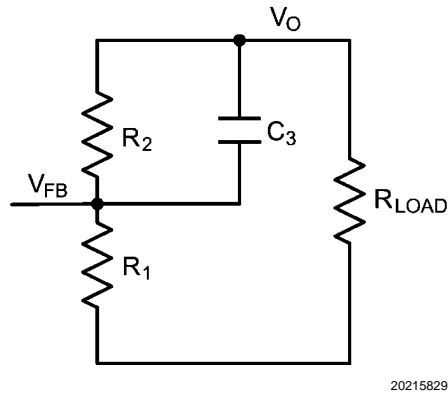

20215829

FIGURE 8. Setting External Pole-Zero

$$F_{\text{ZERO-CF}} = \frac{1}{2\pi(R_2 \times C_3)}$$

There is an associated pole with the zero that was created in the above equation.

$$F_{\text{POLE-CF}} = \frac{1}{2\pi((R_1 \parallel R_2) \times C_3)}$$

It is always higher in frequency than the zero.

A right-half plane zero (RHPZ) is inherent to all boost converters. One must remember that the gain associated with a right-half plane zero increases at 20dB per decade, but the phase decreases by 45° per decade. For most applications there is little concern with the RHPZ due to the fact that the frequency at which it shows up is well beyond crossover, and has little to no effect on loop stability. One must be concerned with this condition for large inductor values and high output currents.

$$\text{RHP}_{\text{ZERO}} = \frac{(D')^2 R_{\text{Load}}}{2\pi \times L}$$

There are miscellaneous poles and zeros associated with parasitics internal to the LM2735, external components, and the PCB. They are located well over the crossover frequency, and for simplicity are not discussed.

PCB Layout Considerations

When planning layout there are a few things to consider when trying to achieve a clean, regulated output. The most important consideration when completing a Boost Converter layout is the close coupling of the GND connections of the C_{OUT} capacitor and the LM2735 PGND pin. The GND ends should be close to one another and be connected to the GND plane with at least two through-holes. There should be a continuous ground plane on the bottom layer of a two-layer board except under the switching node island. The FB pin is a high impedance node and care should be taken to make the FB trace short to avoid noise pickup and inaccurate regulation. The feedback resistors should be placed as close as possible to the IC, with the AGND of R1 placed as close as possible to the GND (pin 5 for the LLP) of the IC. The V_{OUT} trace to R2 should be routed away from the inductor and any other traces that are switching. High AC currents flow through the V_{IN} , SW and V_{OUT} traces, so they should be as short and wide as possible. However, making the traces wide increases radiated noise, so the designer must make this trade-off. Radiated noise can be decreased by choosing a shielded inductor. The remaining components should also be placed as close as possible to the IC. Please see Application Note AN-1229 for further considerations and the LM2735 demo board as an example of a four-layer layout. Below is an example of a good thermal & electrical PCB design. This is very similar to our LM2735 demonstration boards that are obtainable via the National Semiconductor website. The demonstration board consists of a two layer PCB with a common input and output voltage application. Most of the routing is on the top layer, with the bottom layer consisting of a large ground plane. The placement of the external components satisfies the electrical considerations, and the thermal performance has been improved by adding thermal vias and a top layer "Dog-Bone".

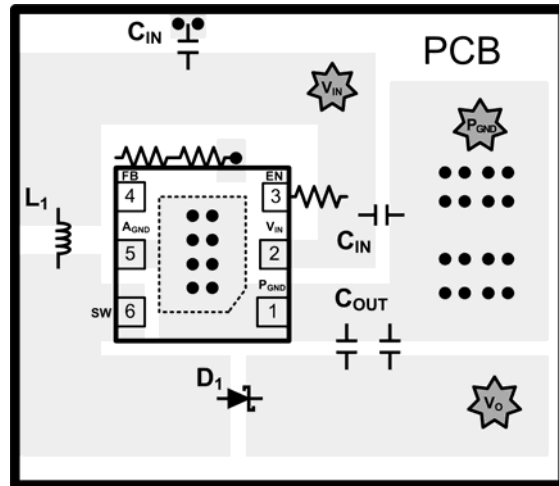
Example of Proper PCB Layout

20215840

FIGURE 9. Boost PCB Layout Guidelines

Thermal Design

When designing for thermal performance, one must consider many variables:

Ambient Temperature: The surrounding maximum air temperature is fairly explanatory. As the temperature increases, the junction temperature will increase. This may not be linear though. As the surrounding air temperature increases, resistances of semiconductors, wires and traces increase. This will decrease the efficiency of the application, and more power will be converted into heat, and will increase the silicon junction temperatures further.

Forced Airflow: Forced air can drastically reduce the device junction temperature. Air flow reduces the hot spots within a design. Warm airflow is often much better than a lower ambient temperature with no airflow.

External Components: Choose components that are efficient, and you can reduce the mutual heating between devices.

PCB design with thermal performance in mind:

The PCB design is a very important step in the thermal design procedure. The LM2735 is available in three package options (5 pin SOT23, 8 pin eMSOP & 6 pin LLP). The options are electrically the same, but difference between the packages is size and thermal performance. The LLP and eMSOP have thermal Die Attach Pads (DAP) attached to the bottom of the packages, and are therefore capable of dissipating more heat than the SOT23 package. It is important that the customer choose the correct package for the application. A detailed thermal design procedure has been included in this data sheet. This procedure will help determine which package is correct, and common applications will be analyzed.

There is one significant thermal PCB layout design consideration that contradicts a proper electrical PCB layout design consideration. This contradiction is the placement of external components that dissipate heat. The greatest external heat contributor is the external Schottky diode. It would be nice if you were able to separate by distance the LM2735 from the Schottky diode, and thereby reducing the mutual heating effect. This will however create electrical performance issues. It is important to keep the LM2735, the output capacitor, and Schottky diode physically close to each other (see PCB layout guidelines). The electrical design considerations outweigh the thermal considerations. Other factors that influence thermal performance are thermal vias, copper weight, and number of board layers.

Definitions

Heat energy is transferred from regions of high temperature to regions of low temperature via three basic mechanisms: radiation, conduction and convection.

Radiation: Electromagnetic transfer of heat between masses at different temperatures.

Conduction: Transfer of heat through a solid medium.

Convection: Transfer of heat through the medium of a fluid; typically air.

Conduction & Convection will be the dominant heat transfer mechanism in most applications.

$R_{\theta JA}$: Thermal impedance from silicon junction to ambient air temperature.

$R_{\theta JC}$: Thermal impedance from silicon junction to device case temperature.

$C_{\theta JC}$: Thermal Delay from silicon junction to device case temperature.

$C_{\theta CA}$: Thermal Delay from device case to ambient air temperature.

$R_{\theta JA}$ & $R_{\theta JC}$: These two symbols represent thermal impedances, and most data sheets contain associated values for these two symbols. The units of measurement are °C/Watt.

$R_{\theta JA}$ is the sum of smaller thermal impedances (see simplified thermal model below). The capacitors represent delays that are present from the time that power and its associated heat is increased or decreased from steady state in one medium until the time that the heat increase or decrease reaches steady state on the another medium.

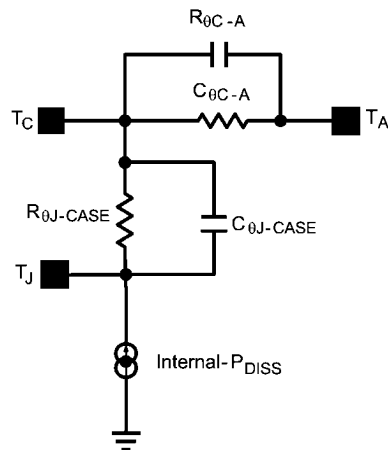

20215841

FIGURE 10. Simplified Thermal Impedance Model

The datasheet values for these symbols are given so that one might compare the thermal performance of one package against another. In order to achieve a comparison between packages, all other variables must be held constant in the comparison (PCB size, copper weight, thermal vias, power dissipation, V_{IN} , V_{OUT} , Load Current etc). This does shed light on the package performance, but it would be a mistake to use these values to calculate the actual junction temperature in your application.

$$R_{\theta JA} = \frac{T_J - T_A}{P_{Dissipation}}$$

We will talk more about calculating the variables of this equation later, and how to eventually calculate a proper junction temperature with relative certainty. For now we need to define the process of calculating the junction temperature and clarify some common misconceptions.

$R_{\theta JA}$ [Variables]:

- Input Voltage, Output Voltage, Output Current, R_{DSon} .
- Ambient temperature & air flow.
- Internal & External components power dissipation.
- Package thermal limitations.
- PCB variables (copper weight, thermal via's, layers component placement).

It would be wrong to assume that the top case temperature is the proper temperature when calculating $R_{\theta JC}$ value. The $R_{\theta JC}$ value represents the thermal impedance of all six sides of a package, not just the top side. This document will refer to a thermal impedance called $R_{\psi JC}$. $R_{\psi JC}$ represents a thermal impedance associated with just the top case temperature. This will allow one to calculate the junction temperature with a thermal sensor connected to the top case.

LM2735 Thermal Models

Heat is dissipated from the LM2735 and other devices. The external loss elements include the Schottky diode, inductor, and loads. All loss elements will mutually increase the heat on the PCB, and therefore increase each other's temperatures.

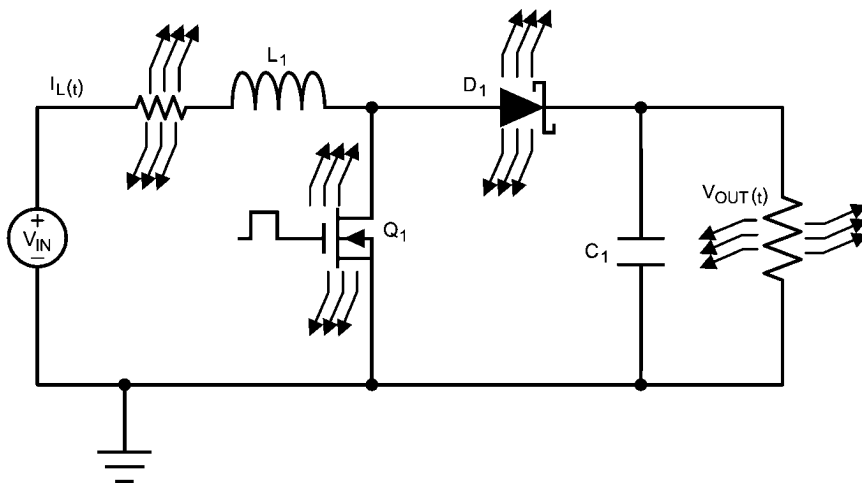

20215843

FIGURE 11. Thermal Schematic

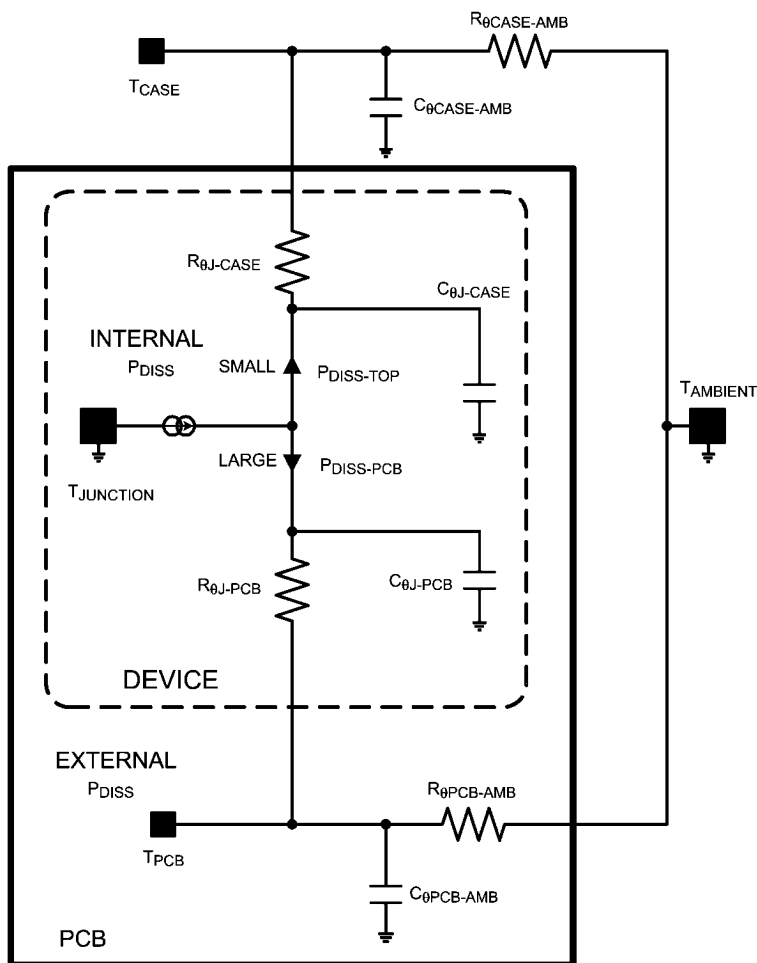

20215844

FIGURE 12. Associated Thermal Model

Calculating Efficiency, and Junction Temperature

The complete LM2735 DC/DC converter efficiency (η) can be calculated in the following manner.

$$\eta = \frac{P_{OUT}}{P_{IN}}$$

or

$$\eta = \frac{P_{OUT}}{P_{OUT} + P_{LOSS}}$$

Power loss (P_{LOSS}) is the sum of two types of losses in the converter, switching and conduction. Conduction losses usually dominate at higher output loads, whereas switching losses remain relatively fixed and dominate at lower output loads.

Losses in the LM2735 Device: $P_{LOSS} = P_{COND} + P_{SW} + P_Q$

Conversion ratio of the Boost Converter with conduction loss elements inserted:

$$\frac{V_{OUT}}{V_{IN}} = \frac{1}{D'} \left(1 - \frac{D' \times V_D}{V_{IN}} \right) \left(\frac{1}{1 + \frac{R_{DCR} + (D \times R_{DSON})}{D'^2 R_{OUT}}} \right)$$

One can see that if the loss elements are reduced to zero, the conversion ratio simplifies to:

$$\frac{V_{OUT}}{V_{IN}} = \frac{1}{D'}$$

And we know:

$$\frac{V_{OUT}}{V_{IN}} = \frac{\eta}{D'}$$

Therefore:

$$\eta = D' \frac{V_{OUT}}{V_{IN}} = \left(\frac{1 - \frac{D' \times V_D}{V_{IN}}}{1 + \frac{R_{DCR} + (D \times R_{DSON})}{D'^2 R_{OUT}}} \right)$$

Calculations for determining the most significant power losses are discussed below. Other losses totaling less than 2% are not discussed.

A simple efficiency calculation that takes into account the conduction losses is shown below:

$$\eta \approx \left(\frac{1 - \frac{D' \times V_D}{V_{IN}}}{1 + \frac{R_{DCR} + (D \times R_{DSON})}{D'^2 R_{OUT}}} \right)$$

The diode, NMOS switch, and inductor DCR losses are included in this calculation. Setting any loss element to zero will simplify the equation.

V_D is the forward voltage drop across the Schottky diode. It can be obtained from the manufacturer's Electrical Characteristics section of the data sheet.

The conduction losses in the diode are calculated as follows:

$$P_{\text{DIODE}} = V_D \times I_O$$

Depending on the duty cycle, this can be the single most significant power loss in the circuit. Care should be taken to choose a diode that has a low forward voltage drop. Another concern with diode selection is reverse leakage current. Depending on the ambient temperature and the reverse voltage across the diode, the current being drawn from the output to the NMOS switch during time D could be significant, this may increase losses internal to the LM2735 and reduce the overall efficiency of the application. Refer to Schottky diode manufacturer's data sheets for reverse leakage specifications, and typical applications within this data sheet for diode selections.

Another significant external power loss is the conduction loss in the input inductor. The power loss within the inductor can be simplified to:

$$P_{\text{IND}} = I_{\text{IN}}^2 R_{\text{DCR}}$$

$$P_{\text{IND}} = \left(\frac{I_O^2 R_{\text{DCR}}}{D'} \right)$$

The LM2735 conduction loss is mainly associated with the internal NFET:

$$P_{\text{COND-NFET}} = I_{\text{SW-rms}}^2 \times R_{\text{DSON}} \times D$$

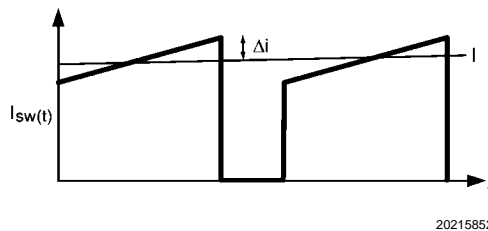

FIGURE 13. LM2735 Switch Current

$$I_{\text{SW-rms}} = I_{\text{IND}} \sqrt{D} \times \sqrt{1 + \frac{1}{3} \left(\frac{\Delta i}{I_{\text{IND}}} \right)^2} \approx I_{\text{IND}} \sqrt{D}$$

$$P_{\text{IND}} = I_{\text{IN}}^2 \times R_{\text{IND-DCR}}$$

(small ripple approximation)

$$P_{\text{COND-NFET}} = I_{\text{IN}}^2 \times R_{\text{DSON}} \times D$$

$$P_{\text{COND-NFET}} = \left(\frac{I_O}{D'} \right)^2 \times R_{\text{DSON}} \times D$$

The value for should be equal to the resistance at the junction temperature you wish to analyze. As an example, at 125°C and $V_{\text{IN}} = 5\text{V}$, $R_{\text{DSON}} = 250 \text{ m}\Omega$ (See typical graphs for value).

Switching losses are also associated with the internal NMOS switch. They occur during the switch on and off transition periods, where voltages and currents overlap resulting in power loss.

The simplest means to determine this loss is to empirically measuring the rise and fall times (10% to 90%) of the switch at the switch node:

$$P_{\text{SWR}} = 1/2(V_{\text{OUT}} \times I_{\text{IN}} \times F_{\text{SW}} \times T_{\text{RISE}})$$

$$P_{\text{SWF}} = 1/2(V_{\text{OUT}} \times I_{\text{IN}} \times F_{\text{SW}} \times T_{\text{FALL}})$$

$$P_{\text{SW}} = P_{\text{SWR}} + P_{\text{SWF}}$$

Typical Switch-Node Rise and Fall Times

V_{IN}	V_{OUT}	T_{RISE}	T_{FALL}
3V	5V	6nS	4nS
5V	12V	6nS	5nS
3V	12V	7nS	5nS
5V	18V	7nS	5nS

Quiescent Power Losses

I_Q is the quiescent operating current, and is typically around 4mA.

$$P_Q = I_Q \times V_{IN}$$

Example Efficiency Calculation:

TABLE 1. Operating Conditions

V_{IN}	5V
V_{OUT}	12V
I_{OUT}	500mA
V_D	0.4V
F_{SW}	1.60MHz
I_Q	4mA
T_{RISE}	6nS
T_{FALL}	5nS
R_{DSon}	250m Ω
R_{DCR}	50m Ω
D	0.64
I_{IN}	1.4A

$$\Sigma P_{COND} + P_{SW} + P_{DIODE} + P_{IND} + P_Q = P_{LOSS}$$

Quiescent Power Losses

$$P_Q = I_Q \times V_{IN} = 20 \text{ mW}$$

Switching Power Losses

$$P_{SWR} = 1/2(V_{OUT} \times I_{IN} \times F_{SW} \times T_{RISE}) \cong 6 \text{ ns} \cong 80 \text{ mW}$$

$$P_{SWF} = 1/2(V_{OUT} \times I_{IN} \times F_{SW} \times T_{FALL}) \cong 5 \text{ ns} \cong 70 \text{ mW}$$

$$P_{SW} = P_{SWR} + P_{SWF} = 150 \text{ mW}$$

Internal NFET Power Losses

$$R_{DSon} = 250 \text{ m}\Omega$$

$$P_{CONDUCTION} = I_{IN}^2 \times D \times R_{DSon} \times 305 \text{ mW}$$

Diode Losses

$$V_D = 0.45V$$

$$P_{DIODE} = V_D \times I_{IN}(1-D) = 236 \text{ mW}$$

Inductor Power Losses

$$R_{DCR} = 75 \text{ m}\Omega$$

$$P_{IND} = I_{IN}^2 \times R_{DCR} = 145 \text{ mW}$$

Total Power Losses are:

TABLE 2. Power Loss Tabulation

V_{IN}	5V		
V_{OUT}	12V		
I_{OUT}	500mA	POUT	6W
V_D	0.4V	PDIODE	236mW
F_{SW}	1.6MHz		
T_{RISE}	6nS	PSWR	80mW
T_{FALL}	5nS	PSWF	70mW
I_Q	4mA	PQ	20mW
R_{DSon}	250m Ω	PCOND	305mW
R_{DCR}	75m Ω	PIND	145mW
D	0.623		
η	86%	PLOSS	856mW

$$P_{\text{INTERNAL}} = P_{\text{COND}} + P_{\text{SW}} = 475 \text{ mW}$$

Calculating $R_{\theta JA}$ and $R_{\psi JC}$

$$R_{\theta JA} = \frac{T_J - T_A}{P_{\text{Dissipation}}}$$

and

$$R_{\psi JC} = \frac{T_J - T_{\text{CASE}}}{P_{\text{Dissipation}}}$$

We now know the internal power dissipation, and we are trying to keep the junction temperature at or below 125°C. The next step is to calculate the value for $R_{\theta JA}$ and/or $R_{\psi JC}$. This is actually very simple to accomplish, and necessary if you think you may be marginal with regards to thermals or determining what package option is correct.

The LM2735 has a thermal shutdown comparator. When the silicon reaches a temperature of 160°C, the device shuts down until the temperature reduces to 150°C. Knowing this, one can calculate the $R_{\theta JA}$ or the $R_{\psi JC}$ of a specific application. Because the junction to top case thermal impedance is much lower than the thermal impedance of junction to ambient air, the error in calculating $R_{\psi JC}$ is lower than for $R_{\theta JA}$. However, you will need to attach a small thermocouple onto the top case of the LM2735 to obtain the $R_{\psi JC}$ value.

Knowing the temperature of the silicon when the device shuts down allows us to know three of the four variables. Once we calculate the thermal impedance, we then can work backwards with the junction temperature set to 125°C to see what maximum ambient air temperature keeps the silicon below the 125°C temperature.

Procedure:

Place your application into a thermal chamber. You will need to dissipate enough power in the device so you can obtain a good thermal impedance value.

Raise the ambient air temperature until the device goes into thermal shutdown. Record the temperatures of the ambient air and/or the top case temperature of the LM2735. Calculate the thermal impedances.

Example from previous calculations:

$$P_{\text{diss}} = 475 \text{ mW}$$

$$T_a \text{ @ Shutdown} = 139^\circ\text{C}$$

$$T_c \text{ @ Shutdown} = 155^\circ\text{C}$$

$$R_{\theta JA} = \frac{T_J - T_A}{P_{\text{Dissipation}}} : R_{\psi JC} = \frac{T_J - T_{\text{Case-Top}}}{P_{\text{Dissipation}}}$$

$$R_{\theta JA} \text{ LLP} = 55^\circ\text{C/W}$$

$$R_{\psi JC} \text{ LLP} = 21^\circ\text{C/W}$$

LLP & eMSOP typical applications will produce $R_{\theta JA}$ numbers in the range of 50°C/W to 65°C/W, and $R_{\psi JC}$ will vary between 18°C/W and 28°C/W. These values are for PCB's with two and four layer boards with 0.5 oz copper, and four to six thermal vias to bottom side ground plane under the DAP.

For 5-pin SOT23 package typical applications, $R_{\theta JA}$ numbers will range from 80°C/W to 110°C/W, and $R_{\psi JC}$ will vary between 50°C/W and 65°C/W. These values are for PCB's with two & four layer boards with 0.5 oz copper, with two to four thermal vias from GND pin to bottom layer.

Here is a good rule of thumb for typical thermal impedances, and an ambient temperature maximum of 75°C: If your design requires that you dissipate more than 400mW internal to the LM2735, or there is 750mW of total power loss in the application, it is recommended that you use the 6 pin LLP or the 8 pin eMSOP package.

Note: To use these procedures it is important to dissipate an amount of power within the device that will indicate a true thermal impedance value. If one uses a very small internal dissipated value, one can see that the thermal impedance calculated is abnormally high, and subject to error. The graph below shows the nonlinear relationship of internal power dissipation vs. $R_{\theta JA}$.

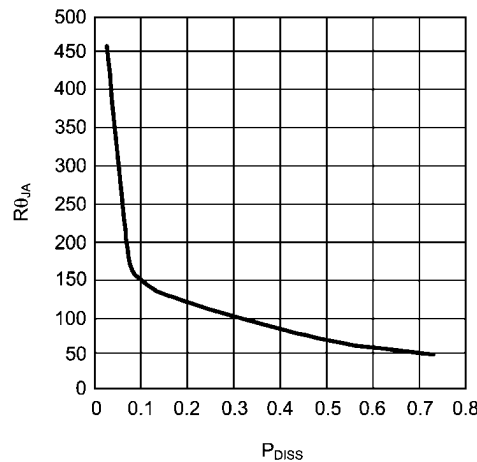

20215856

FIGURE 14. R_{θJA} vs Internal Dissipation for the LLP-6 and eMSOP-8 Package

SEPIC Converter

The LM2735 can easily be converted into a SEPIC converter. A SEPIC converter has the ability to regulate an output voltage that is either larger or smaller in magnitude than the input voltage. Other converters have this ability as well (CUK and Buck-Boost), but usually create an output voltage that is opposite in polarity to the input voltage. This topology is a perfect fit for Lithium Ion battery applications where the input voltage for a single cell Li-Ion battery will vary between 3V & 4.5V and the output voltage is somewhere in between. Most of the analysis of the LM2735 Boost Converter is applicable to the LM2735 SEPIC Converter.

SEPIC Design Guide:

SEPIC Conversion ratio without loss elements:

$$\frac{V_o}{V_{IN}} = \frac{D}{D'}$$

Therefore:

$$D = \frac{V_o}{V_o + V_{IN}}$$

Small ripple approximation:

In a well-designed SEPIC converter, the output voltage, and input voltage ripple, the inductor ripple and is small in comparison to the DC magnitude. Therefore it is a safe approximation to assume a DC value for these components. The main objective of the Steady State Analysis is to determine the steady state duty-cycle, voltage and current stresses on all components, and proper values for all components.

In a steady-state converter, the net volt-seconds across an inductor after one cycle will equal zero. Also, the charge into a capacitor will equal the charge out of a capacitor in one cycle.

Therefore:

$$I_{L2} = \left(\frac{D}{D'} \right) \times I_{L1}$$

and

$$I_{L1} = \left(\frac{D}{D'} \right) \times \left(\frac{V_o}{R} \right)$$

Substituting I_{L1} into I_{L2}

$$I_{L2} = \frac{V_O}{R}$$

The average inductor current of L2 is the average output load.

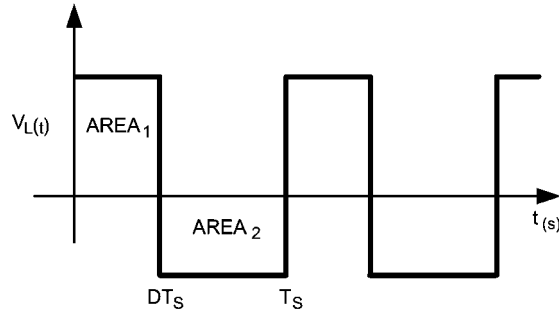

20215863

FIGURE 15. Inductor Volt-Sec Balance Waveform

Applying Charge balance on C1:

$$V_{C1} = \frac{D'(V_o)}{D}$$

Since there are no DC voltages across either inductor, and capacitor C6 is connected to \$V_{in}\$ through L1 at one end, or to ground through L2 on the other end, we can say that

$$V_{C1} = V_{IN}$$

Therefore:

$$V_{IN} = \frac{D'(V_o)}{D}$$

This verifies the original conversion ratio equation.

It is important to remember that the internal switch current is equal to \$I_{L1}\$ and \$I_{L2}\$ during the D interval. Design the converter so that the minimum guaranteed peak switch current limit (2.1A) is not exceeded.

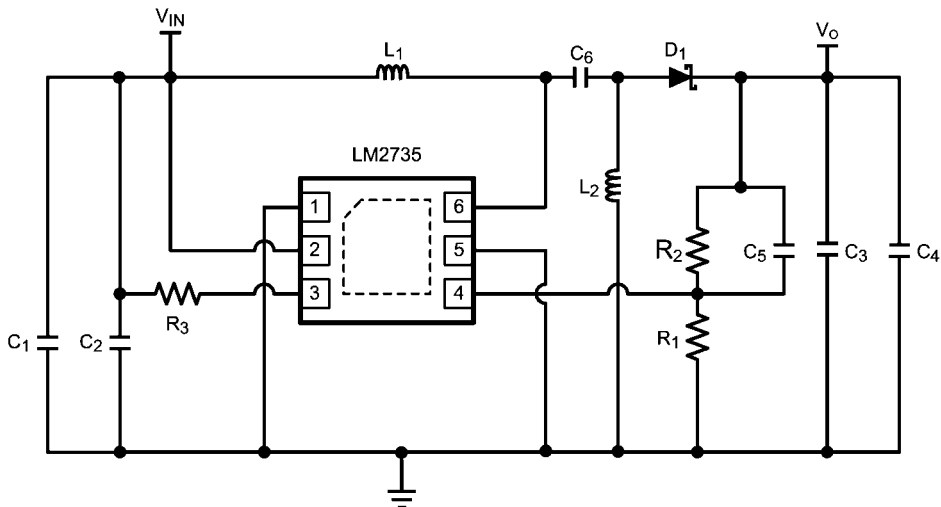

20215880

FIGURE 16. SEPIC CONVERTER Schematic

Steady State Analysis with Loss Elements

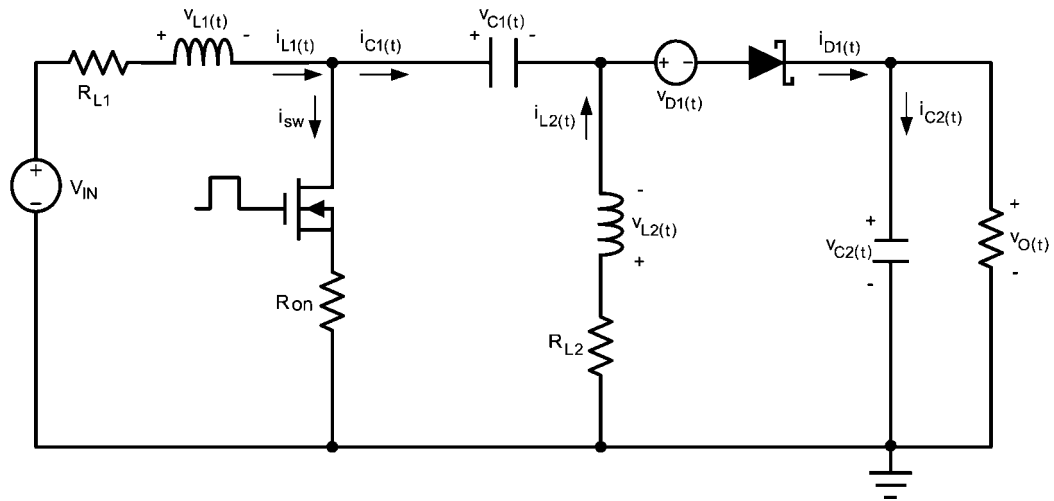

20215866

Using inductor volt-second balance & capacitor charge balance, the following equations are derived:

$$I_{L2} = \left(\frac{V_O}{R} \right)$$

and

$$I_{L1} = \left(\frac{V_O}{R} \right) \times \left(\frac{D}{D'} \right)$$

$$\frac{V_o}{V_{IN}} = \left(\frac{D}{D'} \right) \left(\frac{1}{\left(1 + \frac{V_D}{V_O} + \frac{R_{L2}}{R} \right) + \left(\frac{D}{D^2} \right) \left(\frac{R_{ON}}{R} \right) + \left(\frac{D^2}{D'^2} \right) \left(\frac{R_{L1}}{R} \right)} \right)$$

Therefore:

$$\eta = \left(\frac{1}{\left(1 + \frac{V_D}{V_O} + \frac{R_{L2}}{R} \right) + \left(\frac{D}{D^2} \right) \left(\frac{R_{ON}}{R} \right) + \left(\frac{D^2}{D'^2} \right) \left(\frac{R_{L1}}{R} \right)} \right)$$

One can see that all variables are known except for the duty cycle (D). A quadratic equation is needed to solve for D. A less accurate method of determining the duty cycle is to assume efficiency, and calculate the duty cycle.

$$\frac{V_O}{V_{IN}} = \left(\frac{D}{1-D} \right) \times \eta$$

$$D = \left(\frac{V_O}{(V_{IN} \times \eta) + V_O} \right)$$

V _{in}	2.7V	V _{in}	3.3V	V _{in}	5V
V _o	3.1V	V _o	3.1V	V _o	3.1V
I _{in}	770 mA	I _{in}	600 mA	I _{in}	375 mA
I _o	500 mA	I _o	500 mA	I _o	500 mA
η	75%	η	80%	η	83%

20215890

Efficiencies for Typical SEPIC Application

SEPIC Converter PCB Layout

The layout guidelines described for the LM2735 Boost-Converter are applicable to the SEPIC Converter. Below is a proper PCB layout for a SEPIC Converter.

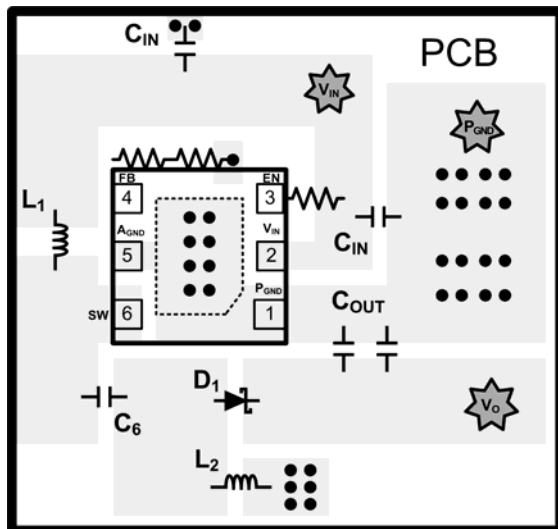

20215872

FIGURE 17. SEPIC PCB Layout

LLP Package

The LM2735 packaged in the 6-pin LLP:

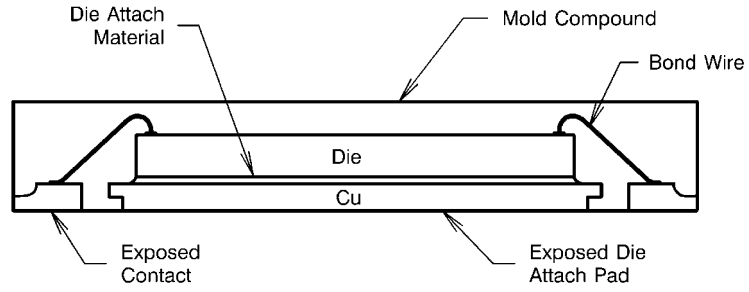

20215873

FIGURE 18. Internal LLP Connection

For certain high power applications, the PCB land may be modified to a "dog bone" shape (see Figure 19). Increasing the size of ground plane, and adding thermal vias can reduce the $R_{\theta JA}$ for the application.

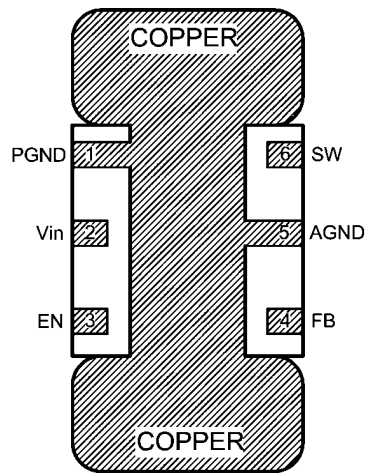

20215874

FIGURE 19. PCB Dog Bone Layout

LM2735Y SOT23-5 Design Example 2

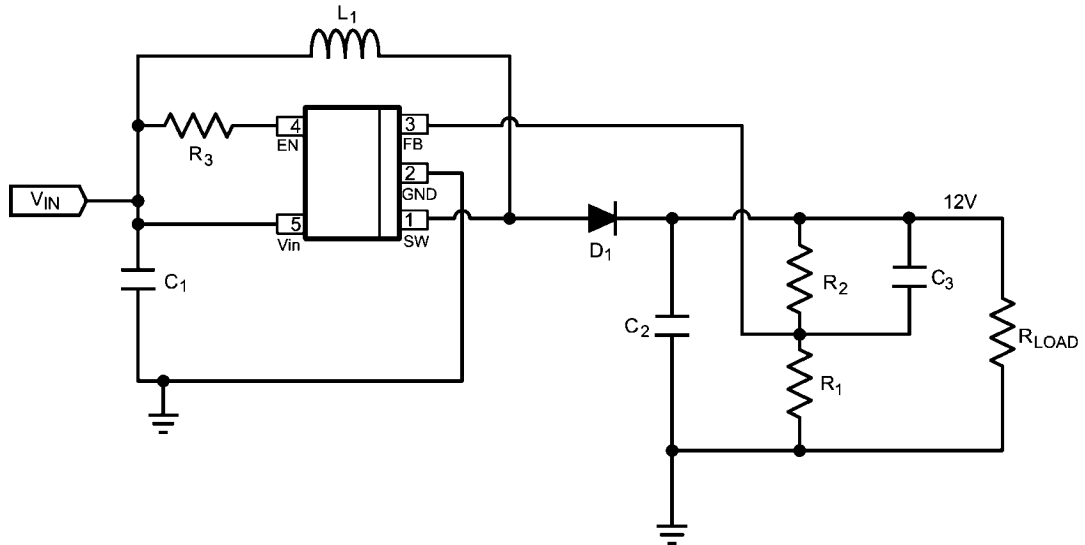

LM2735Y (520kHz): $V_{in} = 5V$, $V_{out} = 12V @ 350mA$

20215875

Part ID	Part Value	Manufacturer	Part Number
U1	2.1A Boost Regulator	NSC	LM2735YMF
C1, Input Cap	22 μ F, 6.3V, X5R	TDK	C2012X5R0J226M
C2 Output Cap	10 μ F, 25V, X5R	TDK	C3216X5R1E106M
C3 Comp Cap	330pF	TDK	C1608X5R1H331K
D1, Catch Diode	0.4V _f Schottky 1A, 20V _R	ST	STPS120M
L1	33 μ H 1.5A	Coilcraft	DS3316P-333ML
R1	10.2k Ω , 1%	Vishay	CRCW06031022F
R2	86.6k Ω , 1%	Vishay	CRCW06038662F
R3	100k Ω , 1%	Vishay	CRCW06031003F

LM2735X LLP-6 Design Example 3

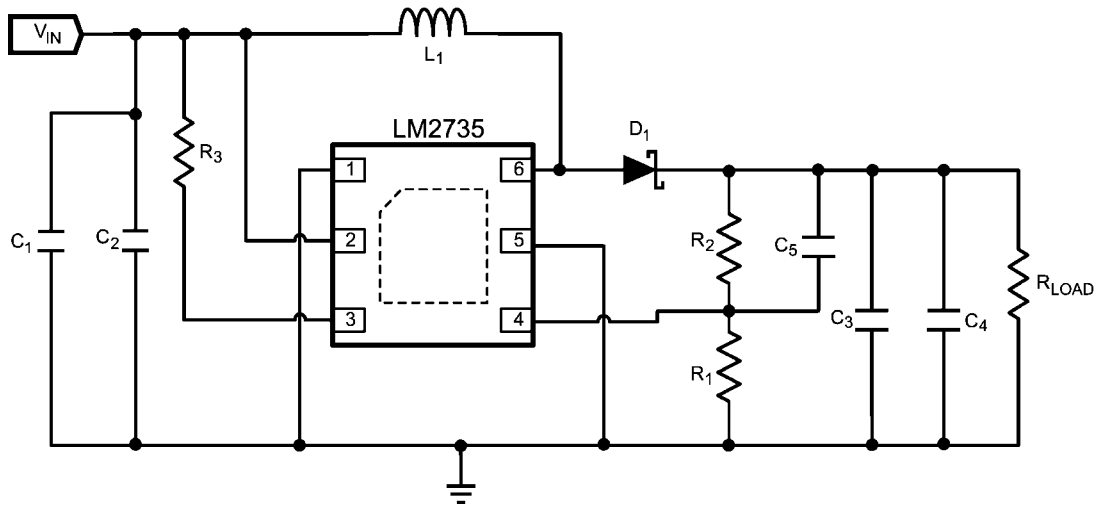

LM2735X (1.6MHz): $V_{in} = 3.3V$, $V_{out} = 12V @ 350mA$

20215876

Part ID	Part Value	Manufacturer	Part Number
U1	2.1A Boost Regulator	NSC	LM2735XSD
C1 Input Cap	22 μ F, 6.3V, X5R	TDK	C2012X5R0J226M
C2 Input Cap	No Load		
C3 Output Cap	10 μ F, 25V, X5R	TDK	C3216X5R1E106M
C4 Output Cap	No Load		
C5 Comp Cap	330pF	TDK	C1608X5R1H331K
D1, Catch Diode	0.4V _f Schottky 1A, 20V _R	ST	STPS120M
L1	6.8 μ H 2A	Coilcraft	DO1813H-682ML
R1	10.2k Ω , 1%	Vishay	CRCW06031022F
R2	86.6k Ω , 1%	Vishay	CRCW06038662F
R3	100k Ω , 1%	Vishay	CRCW06031003F

LM2735Y LLP-6 Design Example 4

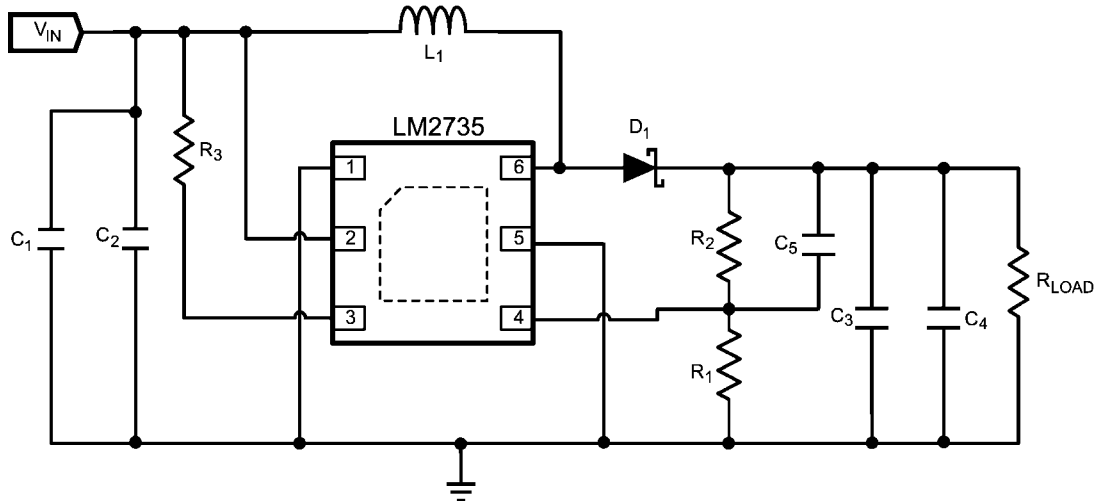

LM2735Y (520kHz): $V_{in} = 3.3V$, $V_{out} = 12V @ 350mA$

20215876

Part ID	Part Value	Manufacturer	Part Number
U1	2.1A Boost Regulator	NSC	LM2735YSD
C1 Input Cap	22 μ F, 6.3V, X5R	TDK	C2012X5R0J226M
C2 Input Cap	No Load		
C3 Output Cap	10 μ F, 25V, X5R	TDK	C3216X5R1E106M
C4 Output Cap	No Load		
C5 Comp Cap	330pF	TDK	C1608X5R1H331K
D1, Catch Diode	0.4V _f Schottky 1A, 20V _R	ST	STPS120M
L1	15 μ H 2A	Coilcraft	MSS5131-153ML
R1	10.2k Ω , 1%	Vishay	CRCW06031022F
R2	86.6k Ω , 1%	Vishay	CRCW06038662F
R3	100k Ω , 1%	Vishay	CRCW06031003F

LM2735Y eMSOP-8 Design Example 5

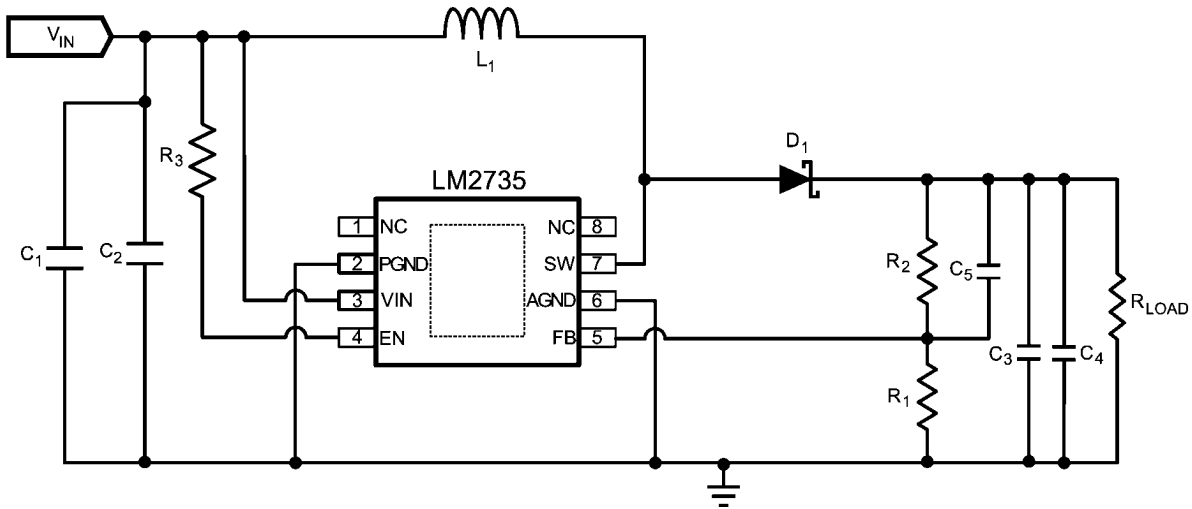

LM2735Y (520kHz): Vin = 3.3V, Vout = 12V @ 350mA

20215877

Part ID	Part Value	Manufacturer	Part Number
U1	2.1A Boost Regulator	NSC	LM2735YMY
C1 Input Cap	22 μ F, 6.3V, X5R	TDK	C2012X5R0J226M
C2 Input Cap	No Load		
C3 Output Cap	10 μ F, 25V, X5R	TDK	C3216X5R1E106M
C4 Output Cap	No Load		
C5 Comp Cap	330pF	TDK	C1608X5R1H331K
D1, Catch Diode	0.4V _f Schottky 1A, 20V _R	ST	STPS120M
L1	15 μ H 1.5A	Coilcraft	MSS5131-153ML
R1	10.2k Ω , 1%	Vishay	CRCW06031022F
R2	86.6k Ω , 1%	Vishay	CRCW06038662F
R3	100k Ω , 1%	Vishay	CRCW06031003F

LM2735X SOT23-5 Design Example 6

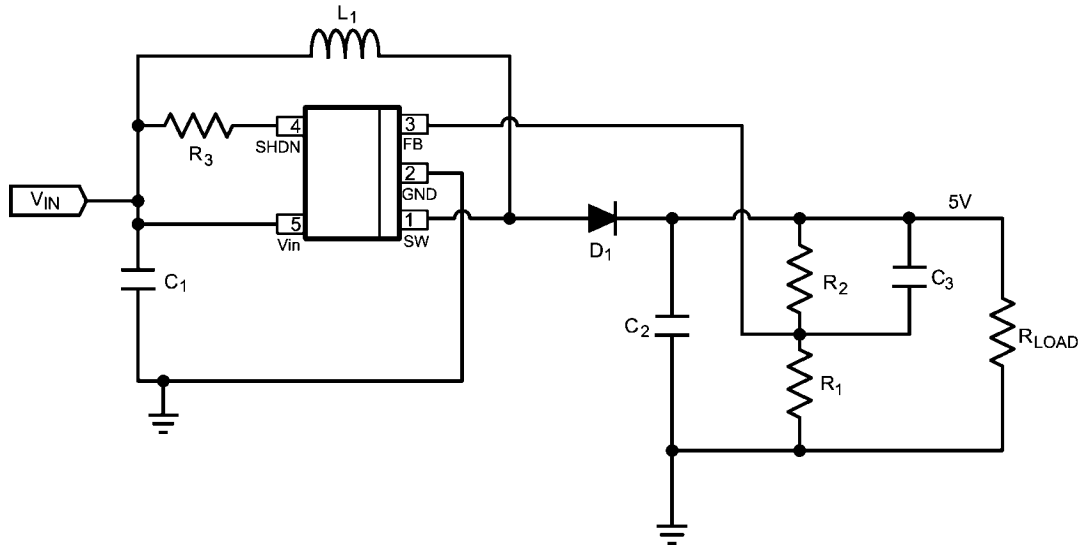

LM2735X (1.6MHz): $V_{in} = 3V$, $V_{out} = 5V @ 500mA$

20215878

Part ID	Part Value	Manufacturer	Part Number
U1	2.1A Boost Regulator	NSC	LM2735XMF
C1, Input Cap	10 μ F, 6.3V, X5R	TDK	C2012X5R0J106K
C2, Output Cap	10 μ F, 6.3V, X5R	TDK	C2012X5R0J106K
C3 Comp Cap	1000pF	TDK	C1608X5R1H102K
D1, Catch Diode	0.4V _f Schottky 1A, 20V _R	ST	STPS120M
L1	10 μ H 1.2A	Coilcraft	DO1608C-103ML
R1	10.0k Ω , 1%	Vishay	CRCW08051002F
R2	30.1k Ω , 1%	Vishay	CRCW08053012F
R3	100k Ω , 1%	Vishay	CRCW06031003F

LM2735Y SOT23-5 Design Example 7

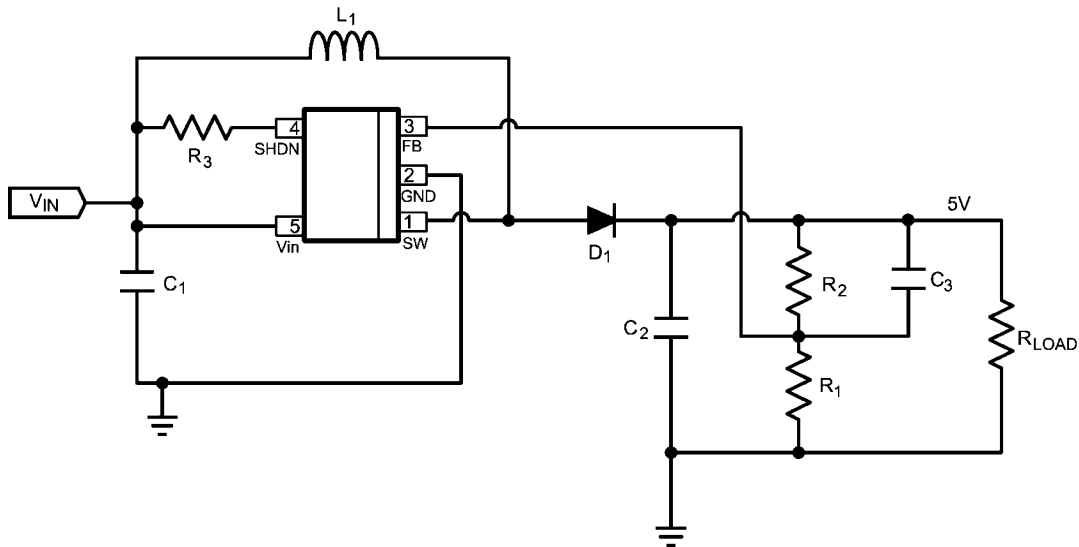

LM2735Y (520kHz): Vin = 3V, Vout = 5V @ 750mA

20215878

Part ID	Part Value	Manufacturer	Part Number
U1	2.1A Boost Regulator	NSC	LM2735YMF
C1 Input Cap	22 μ F, 6.3V, X5R	TDK	C2012X5R0J226M
C2 Output Cap	22 μ F, 6.3V, X5R	TDK	C2012X5R0J226M
C3 Comp Cap	1000pF	TDK	C1608X5R1H102K
D1, Catch Diode	0.4V _f Schottky 1A, 20V _R	ST	STPS120M
L1	22 μ H 1.2A	Coilcraft	MSS5131-223ML
R1	10.0k Ω , 1%	Vishay	CRCW08051002F
R2	30.1k Ω , 1%	Vishay	CRCW08053012F
R3	100k Ω , 1%	Vishay	CRCW06031003F

LM2735X SOT23-5 Design Example 8

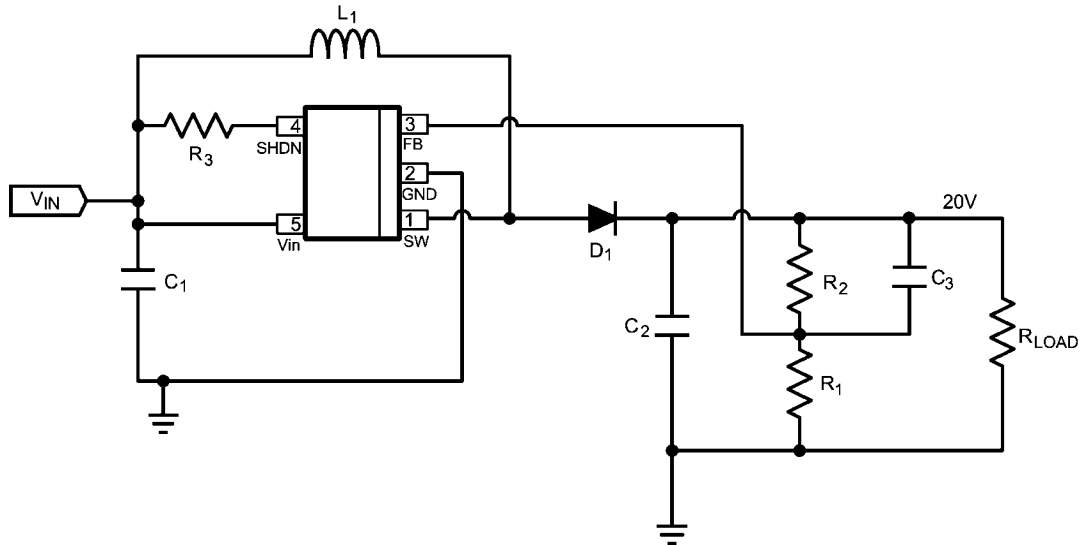

LM2735X (1.6MHz): $V_{in} = 3.3V$, $V_{out} = 20V @ 100mA$

20215879

Part ID	Part Value	Manufacturer	Part Number
U1	2.1A Boost Regulator	NSC	LM2735XMF
C1, Input Cap	22 μ F, 6.3V, X5R	TDK	C2012X5R0J226M
C2, Output Cap	4.7 μ F, 25V, X5R	TDK	C3216X5R1E475K
C3 Comp Cap	470pF	TDK	C1608X5R1H471K
D1, Catch Diode	0.4V _f Schottky 500mA, 30V _R	Vishay	MBR0530
L1	10 μ H 1.2A	Coilcraft	DO1608C-103ML
R1	10.0k Ω , 1%	Vishay	CRCW06031002F
R2	150k Ω , 1%	Vishay	CRCW06031503F
R3	100k Ω , 1%	Vishay	CRCW06031003F

LM2735Y SOT23-5 Design Example 9

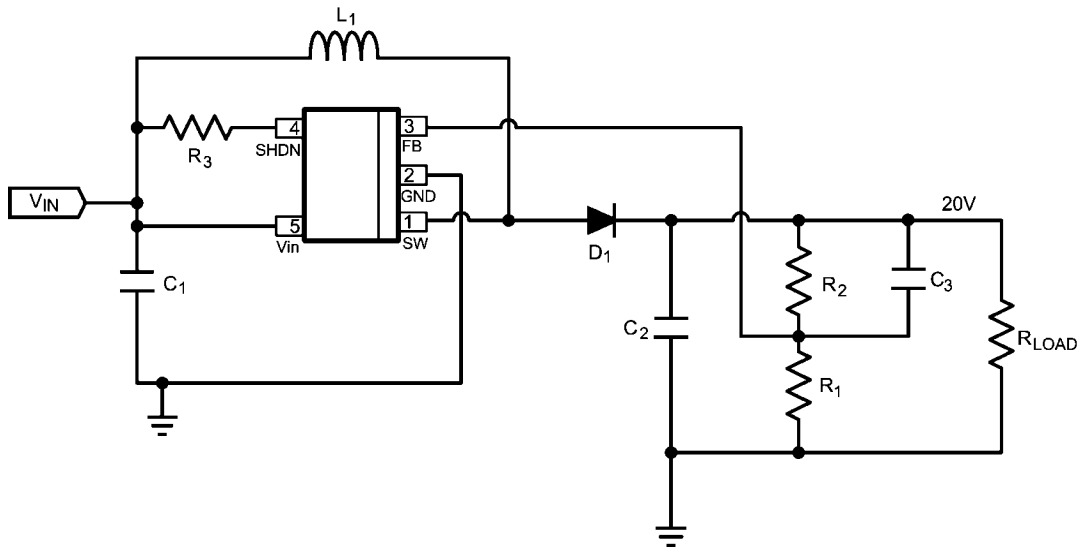

LM2735Y (520kHz): $V_{in} = 3.3V$, $V_{out} = 20V @ 100mA$

20215879

Part ID	Part Value	Manufacturer	Part Number
U1	2.1A Boost Regulator	NSC	LM2735YMF
C1 Input Cap	22 μ F, 6.3V, X5R	TDK	C2012X5R0J226M
C2 Output Cap	10 μ F, 25V, X5R	TDK	C3216X5R1E106M
C3 Comp Cap	470pF	TDK	C1608X5R1H471K
D1, Catch Diode	0.4V _f , Schottky 500mA, 30V _R	Vishay	MBR0530
L1	33 μ H 1.5A	Coilcraft	DS3316P-333ML
R1	10.0k Ω , 1%	Vishay	CRCW06031002F
R2	150.0k Ω , 1%	Vishay	CRCW06031503F
R3	100k Ω , 1%	Vishay	CRCW06031003F

LM2735X LLP-6 Design Example 10

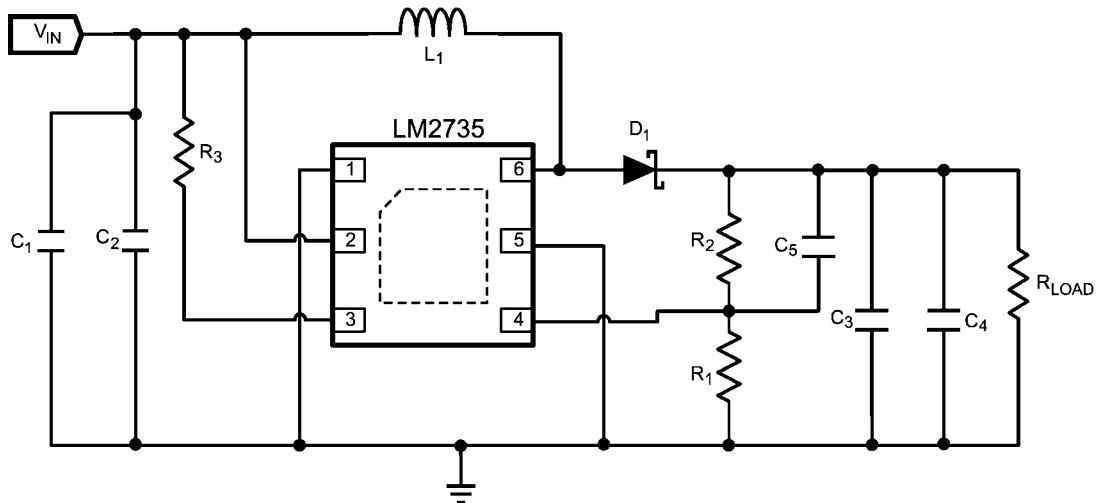

LM2735X (1.6MHz): $V_{in} = 3.3V$, $V_{out} = 20V @ 150mA$

20215876

Part ID	Part Value	Manufacturer	Part Number
U1	2.1A Boost Regulator	NSC	LM2735XSD
C1 Input Cap	22 μ F, 6.3V, X5R	TDK	C2012X5R0J226M
C2 Input Cap	22 μ F, 6.3V, X5R	TDK	C2012X5R0J226M
C3 Output Cap	10 μ F, 25V, X5R	TDK	C3216X5R1E106M
C4 Output Cap	No Load		
C5 Comp Cap	470pF	TDK	C1608X5R1H471K
D1, Catch Diode	0.4V _f Schottky 500mA, 30V _R	Vishay	MBR0530
L1	8.2 μ H 2A	Coilcraft	DO1813H-822ML
R1	10.0k Ω , 1%	Vishay	CRCW06031002F
R2	150k Ω , 1%	Vishay	CRCW06031503F
R3	100k Ω , 1%	Vishay	CRCW06031003F

LM2735Y LLP-6 Design Example 11

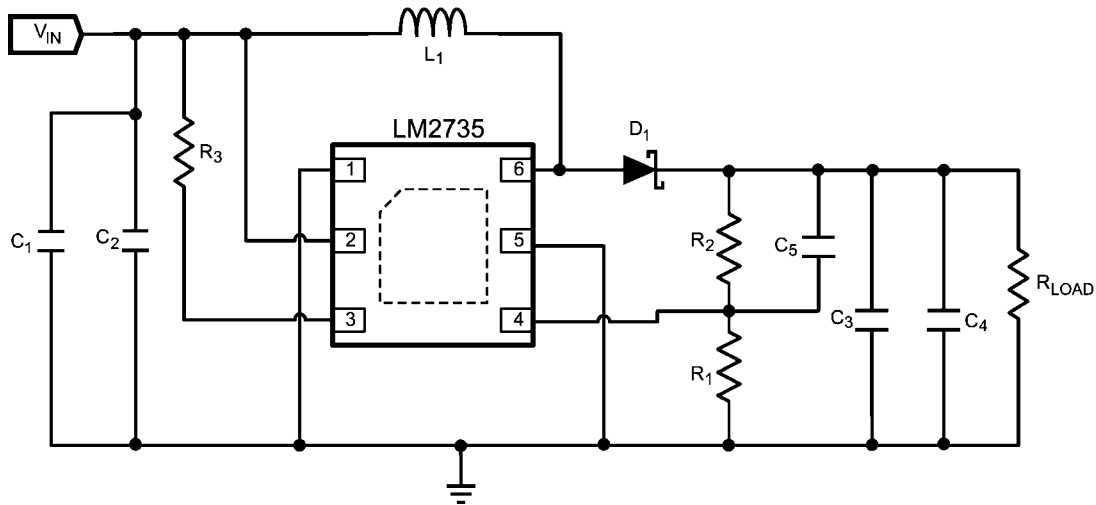

LM2735Y (520kHz): $V_{in} = 3.3V$, $V_{out} = 20V @ 150mA$

20215876

Part ID	Part Value	Manufacturer	Part Number
U1	2.1A Boost Regulator	NSC	LM2735YSD
C1 Input Cap	10 μ F, 6.3V, X5R	TDK	C2012X5R0J106K
C2 Input Cap	10 μ F, 6.3V, X5R	TDK	C2012X5R0J106K
C3 Output Cap	10 μ F, 25V, X5R	TDK	C3216X5R1E106M
C4 Output Cap	No Load		
C5 Comp Cap	470pF	TDK	C1608X5R1H471K
D1, Catch Diode	0.4V _f Schottky 500mA, 30V _R	Vishay	MBR0530
L1	22 μ H 1.5A	Coilcraft	DS3316P-223ML
R1	10.0k Ω , 1%	Vishay	CRCW06031002F
R2	150k Ω , 1%	Vishay	CRCW06031503F
R3	100k Ω , 1%	Vishay	CRCW06031003F

LM2735X LLP-6 SEPIC Design Example 12

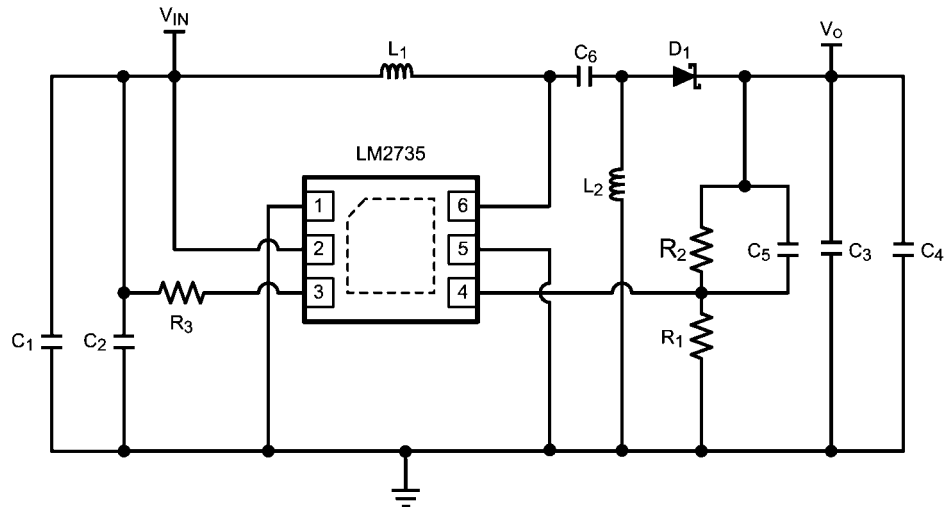

LM2735X (1.6MHz): $V_{in} = 2.7V - 5V$, $V_{out} = 3.3V @ 500mA$

20215880

Part ID	Part Value	Manufacturer	Part Number
U1	2.1A Boost Regulator	NSC	LM2735XSD
C1 Input Cap	22 μ F, 6.3V, X5R	TDK	C2012X5R0J226M
C2 Input Cap	No Load		
C3 Output Cap	10 μ F, 25V, X5R	TDK	C3216X5R1E106M
C4 Output Cap	No Load		
C5 Comp Cap	2200pF	TDK	C1608X5R1H222K
C6	2.2 μ F 16V	TDK	C2012X5R1C225K
D1, Catch Diode	0.4V _f Schottky 1A, 20V _R	ST	STPS120M
L1	6.8 μ H	Coilcraft	DO1608C-682ML
L2	6.8 μ H	Coilcraft	DO1608C-682ML
R1	10.2k Ω , 1%	Vishay	CRCW06031002F
R2	16.5k Ω , 1%	Vishay	CRCW06031652F
R3	100k Ω , 1%	Vishay	CRCW06031003F

LM2735Y eMSOP-8 SEPIC Design Example 13

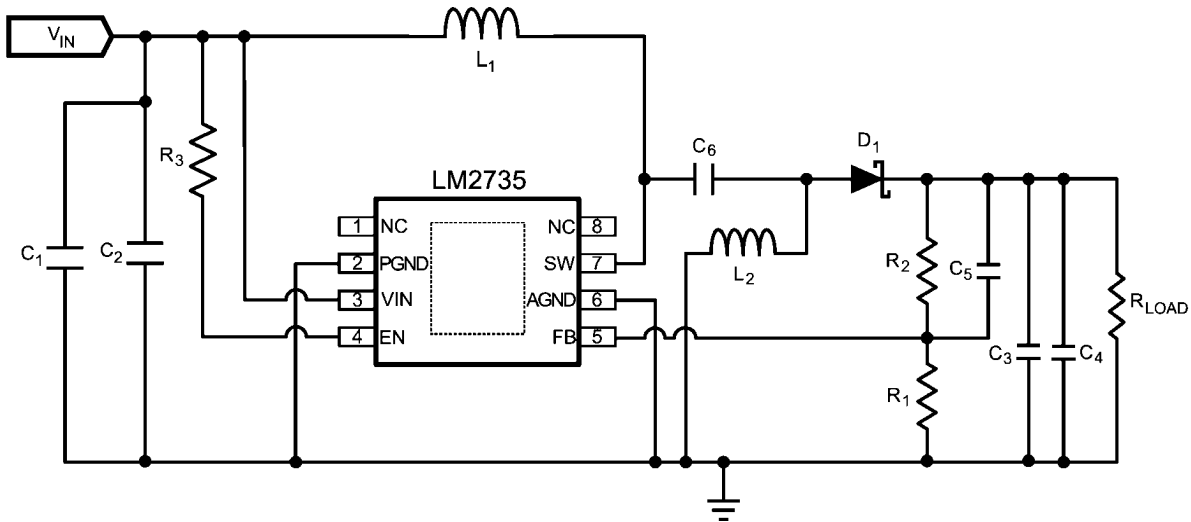

LM2735Y (520kHz): Vin = 2.7V - 5V, Vout = 3.3V @ 500mA

20215881

Part ID	Part Value	Manufacturer	Part Number
U1	2.1A Boost Regulator	NSC	LM2735YMY
C1 Input Cap	22 μ F, 6.3V, X5R	TDK	C2012X5R0J226M
C2 Input Cap	No Load		
C3 Output Cap	10 μ F, 25V, X5R	TDK	C3216X5R1E106M
C4 Output Cap	No Load		
C5 Comp Cap	2200pF	TDK	C1608X5R1H222K
C6	2.2 μ F 16V	TDK	C2012X5R1C225K
D1, Catch Diode	0.4V _f Schottky 1A, 20V _R	ST	STPS120M
L1	15 μ H 1.5A	Coilcraft	MSS5131-153ML
L2	15 μ H 1.5A	Coilcraft	MSS5131-153ML
R1	10.2k Ω , 1%	Vishay	CRCW06031002F
R2	16.5k Ω , 1%	Vishay	CRCW06031652F
R3	100k Ω , 1%	Vishay	CRCW06031003F

LM2735X SOT23-5 LED Design Example 14

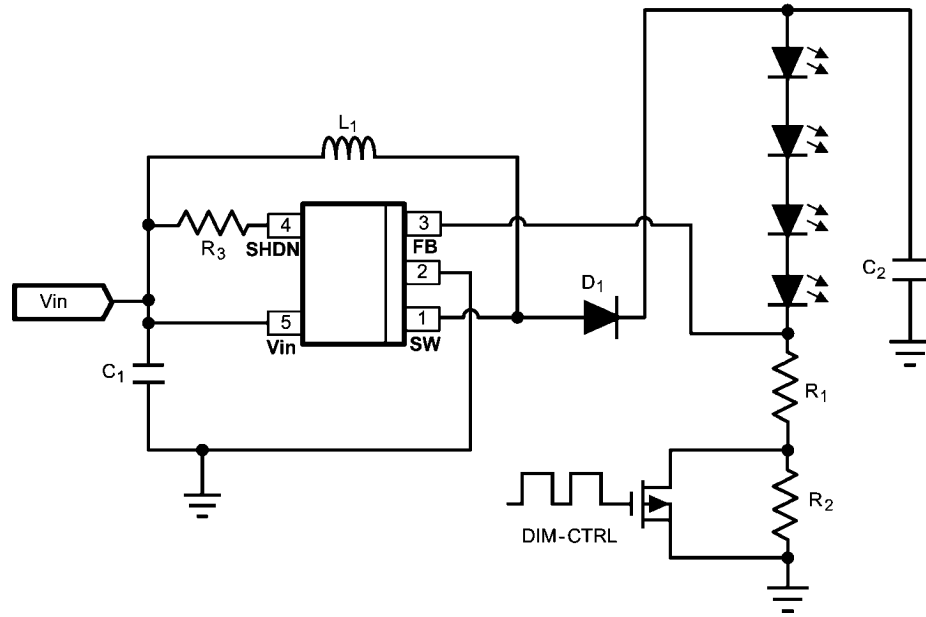

LM2735X (1.6MHz): Vin = 2.7V - 5V, Vout = 20V @ 50mA

20215882

Part ID	Part Value	Manufacturer	Part Number
U1	2.1A Boost Regulator	NSC	LM2735XMF
C1 Input Cap	22 μ F, 6.3V, X5R	TDK	C2012X5R0J226M
C2 Output Cap	4.7 μ F, 25V, X5R	TDK	C3216JB1E475K
D1, Catch Diode	0.4V _f Schottky 500mA, 30V _R	Vishay	MBR0530
L1	15 μ H 1.5A	Coilcraft	MSS5131-153ML
R1	25.5 Ω , 1%	Vishay	CRCW080525R5F
R2	100 Ω , 1%	Vishay	CRCW08051000F
R3	100k Ω , 1%	Vishay	CRCW06031003F

LM2735Y LLP-6 FlyBack Design Example 15

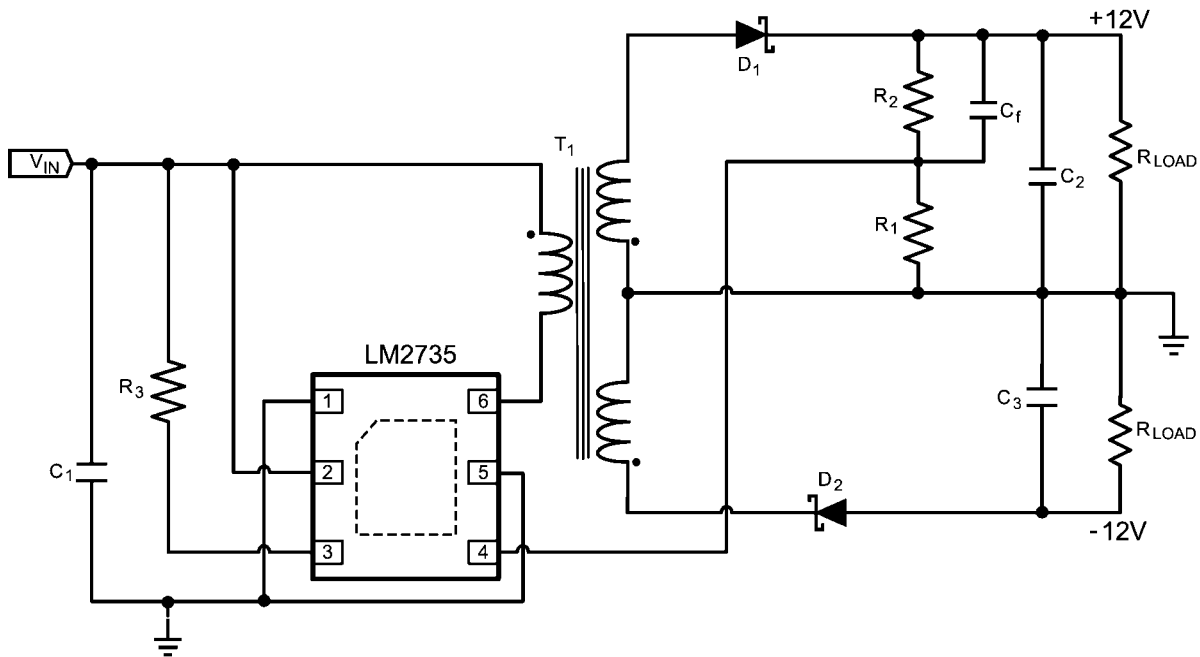

LM2735Y (520kHz): $V_{in} = 5V$, $V_{out} = \pm 12V$ 150mA

20215883

Part ID	Part Value	Manufacturer	Part Number
U1	2.1A Boost Regulator	NSC	LM2735YSD
C1 Input Cap	22 μ F, 6.3V, X5R	TDK	C2012X5R0J226M
C2 Output Cap	10 μ F, 25V, X5R	TDK	C3216X5R1E106M
C3 Output Cap	10 μ F, 25V, X5R	TDK	C3216X5R1E106M
Cf Comp Cap	330pF	TDK	C1608X5R1H331K
D1, D2 Catch Diode	0.4V _f Schottky 500mA, 30V _R	Vishay	MBR0530
T1			
R1	10.0k Ω , 1%	Vishay	CRCW06031002F
R2	86.6k Ω , 1%	Vishay	CRCW06038662F
R3	100k Ω , 1%	Vishay	CRCW06031003F

LM2735X SOT23-5 LED Design Example 16

$V_{\text{RAIL}} > 5.5\text{V}$ Application

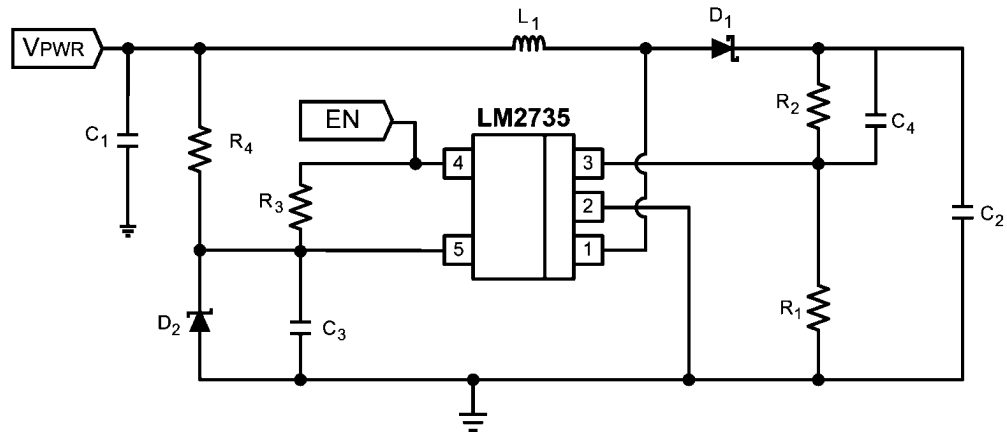

LM2735X (1.6MHz): $V_{\text{PWR}} = 9\text{V}$, $V_{\text{out}} = 12\text{V @ } 500\text{mA}$

202158a3

Part ID	Part Value	Manufacturer	Part Number
U1	2.1A Boost Regulator	NSC	LM2735XMF
C1, Input Cap	10 μF , 6.3V, X5R	TDK	C2012X5R0J106K
C2, Output Cap	10 μF , 25V, X5R	TDK	C3216X5R1E106M
C3 V_{IN} Cap	0.1 μF , 6.3V, X5R	TDK	C2012X5R0J104K
C4 Comp Cap	1000pF	TDK	C1608X5R1H102K
D1, Catch Diode	0.4V _f Schottky 1A, 20V _R	ST	STPS120M
D2	3.3V Zener, SOT23	Diodes Inc	BZX84C3V3
L1	6.8 μH 2A	Coilcraft	DO1813H-682ML
R1	10.0k Ω , 1%	Vishay	CRCW08051002F
R2	86.6k Ω , 1%	Vishay	CRCW08058662F
R3	100k Ω , 1%	Vishay	CRCW06031003F
R4	499 Ω , 1%	Vishay	CRCW06034991F

LM2735X SOT23-5 LED Design Example 17

Two Input Voltage Rail Application

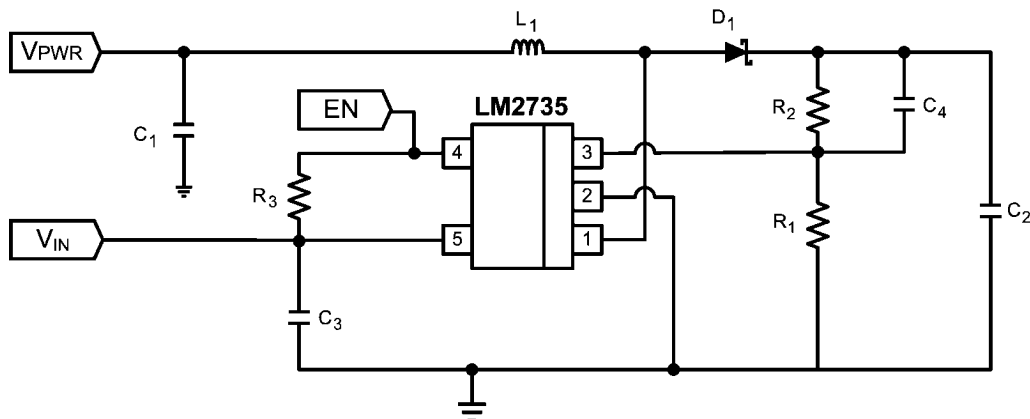

LM2735X (1.6MHz): $V_{PWR} = 9V$ in = 2.7V - 5.5V, $V_{out} = 12V @ 500mA$

202158a4

Part ID	Part Value	Manufacturer	Part Number
U1	2.1A Boost Regulator	NSC	LM2735XMF
C1, Input Cap	10 μ F, 6.3V, X5R	TDK	C2012X5R0J106K
C2, Output Cap	10 μ F, 25V, X5R	TDK	C3216X5R1E106M
C3 V_{IN} Cap	0.1 μ F, 6.3V, X5R	TDK	C2012X5R0J104K
C4 Comp Cap	1000pF	TDK	C1608X5R1H102K
D1, Catch Diode	0.4V _f Schottky 1A, 20V _R	ST	STPS120M
L1	6.8 μ H 2A	Coilcraft	DO1813H-682ML
R1	10.0k Ω , 1%	Vishay	CRCW08051002F
R2	86.6k Ω , 1%	Vishay	CRCW08058662F
R3	100k Ω , 1%	Vishay	CRCW06031003F

Physical Dimensions inches (millimeters) unless otherwise noted

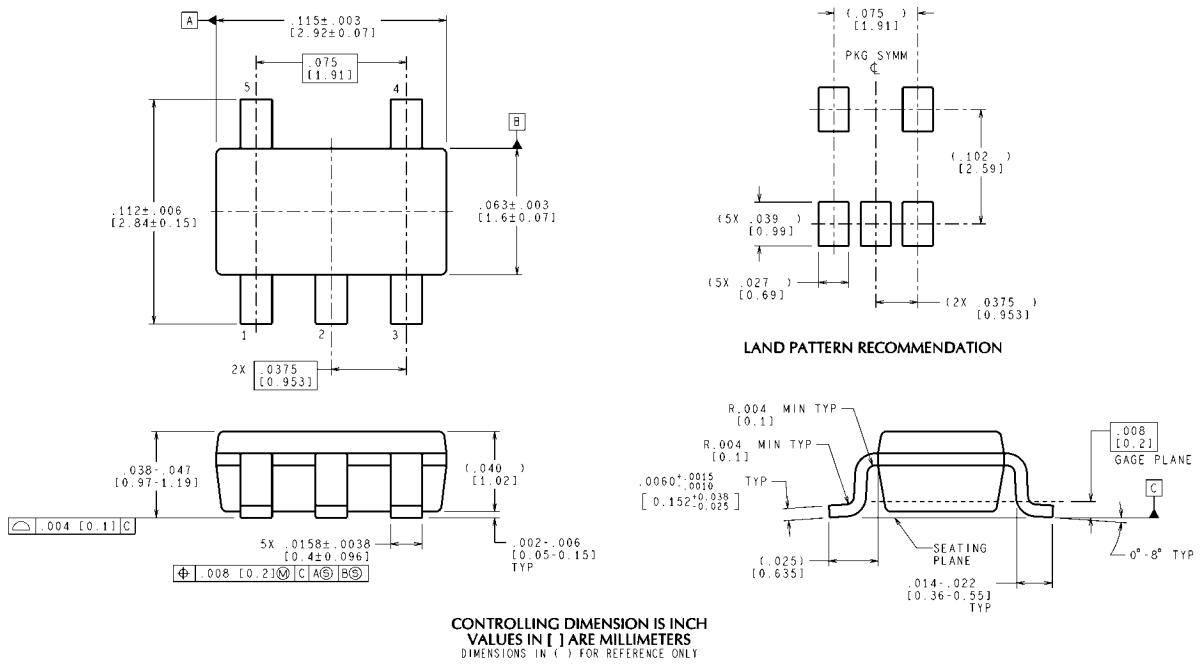
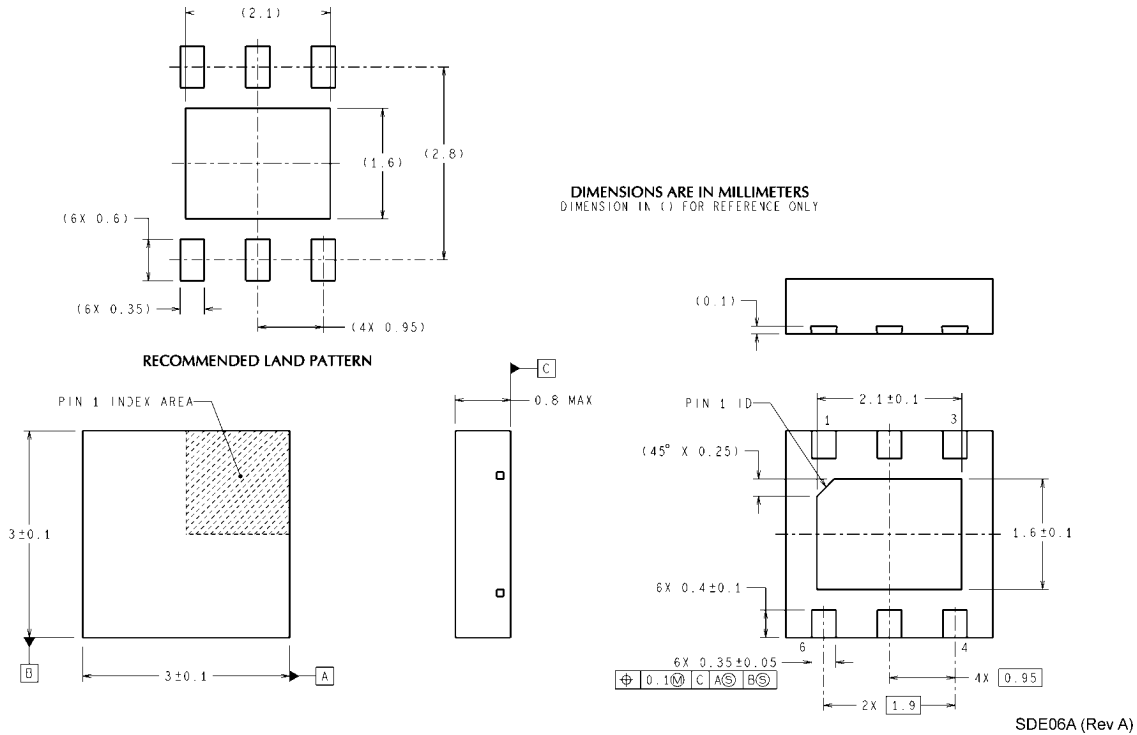

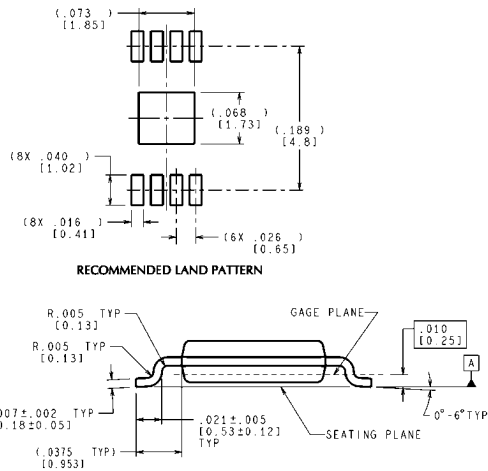
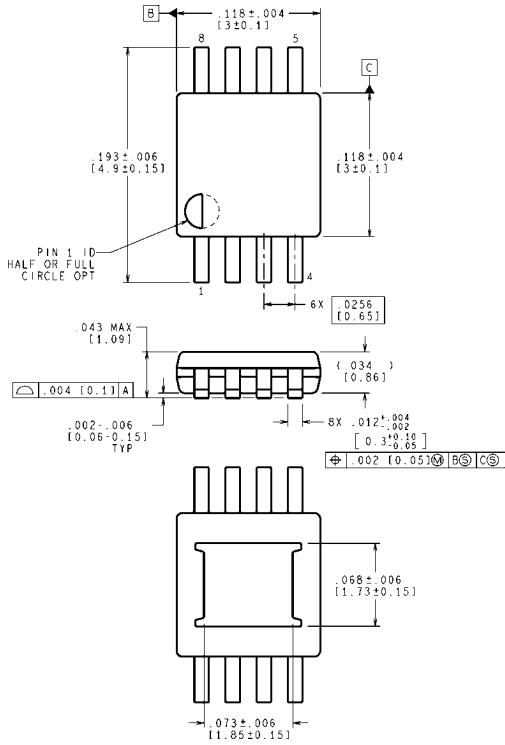

CONTROLLING DIMENSION IS INCH
VALUES IN [] ARE MILLIMETERS

**8-Lead eMSOP Package
NS Package Number MUY08A**

MUY08A (Rev A)

Notes

IMPORTANT NOTICE

Texas Instruments Incorporated and its subsidiaries (TI) reserve the right to make corrections, enhancements, improvements and other changes to its semiconductor products and services per JESD46, latest issue, and to discontinue any product or service per JESD48, latest issue. Buyers should obtain the latest relevant information before placing orders and should verify that such information is current and complete. All semiconductor products (also referred to herein as "components") are sold subject to TI's terms and conditions of sale supplied at the time of order acknowledgment.

TI warrants performance of its components to the specifications applicable at the time of sale, in accordance with the warranty in TI's terms and conditions of sale of semiconductor products. Testing and other quality control techniques are used to the extent TI deems necessary to support this warranty. Except where mandated by applicable law, testing of all parameters of each component is not necessarily performed.

TI assumes no liability for applications assistance or the design of Buyers' products. Buyers are responsible for their products and applications using TI components. To minimize the risks associated with Buyers' products and applications, Buyers should provide adequate design and operating safeguards.

TI does not warrant or represent that any license, either express or implied, is granted under any patent right, copyright, mask work right, or other intellectual property right relating to any combination, machine, or process in which TI components or services are used. Information published by TI regarding third-party products or services does not constitute a license to use such products or services or a warranty or endorsement thereof. Use of such information may require a license from a third party under the patents or other intellectual property of the third party, or a license from TI under the patents or other intellectual property of TI.

Reproduction of significant portions of TI information in TI data books or data sheets is permissible only if reproduction is without alteration and is accompanied by all associated warranties, conditions, limitations, and notices. TI is not responsible or liable for such altered documentation. Information of third parties may be subject to additional restrictions.

Resale of TI components or services with statements different from or beyond the parameters stated by TI for that component or service voids all express and any implied warranties for the associated TI component or service and is an unfair and deceptive business practice. TI is not responsible or liable for any such statements.

Buyer acknowledges and agrees that it is solely responsible for compliance with all legal, regulatory and safety-related requirements concerning its products, and any use of TI components in its applications, notwithstanding any applications-related information or support that may be provided by TI. Buyer represents and agrees that it has all the necessary expertise to create and implement safeguards which anticipate dangerous consequences of failures, monitor failures and their consequences, lessen the likelihood of failures that might cause harm and take appropriate remedial actions. Buyer will fully indemnify TI and its representatives against any damages arising out of the use of any TI components in safety-critical applications.

In some cases, TI components may be promoted specifically to facilitate safety-related applications. With such components, TI's goal is to help enable customers to design and create their own end-product solutions that meet applicable functional safety standards and requirements. Nonetheless, such components are subject to these terms.

No TI components are authorized for use in FDA Class III (or similar life-critical medical equipment) unless authorized officers of the parties have executed a special agreement specifically governing such use.

Only those TI components which TI has specifically designated as military grade or "enhanced plastic" are designed and intended for use in military/aerospace applications or environments. Buyer acknowledges and agrees that any military or aerospace use of TI components which have **not** been so designated is solely at the Buyer's risk, and that Buyer is solely responsible for compliance with all legal and regulatory requirements in connection with such use.

TI has specifically designated certain components which meet ISO/TS16949 requirements, mainly for automotive use. Components which have not been so designated are neither designed nor intended for automotive use; and TI will not be responsible for any failure of such components to meet such requirements.

Products

Audio	www.ti.com/audio
Amplifiers	amplifier.ti.com
Data Converters	dataconverter.ti.com
DLP® Products	www.dlp.com
DSP	dsp.ti.com
Clocks and Timers	www.ti.com/clocks
Interface	interface.ti.com
Logic	logic.ti.com
Power Mgmt	power.ti.com
Microcontrollers	microcontroller.ti.com
RFID	www.ti-rfid.com
OMAP Applications Processors	www.ti.com/omap
Wireless Connectivity	www.ti.com/wirelessconnectivity

Applications

Automotive and Transportation	www.ti.com/automotive
Communications and Telecom	www.ti.com/communications
Computers and Peripherals	www.ti.com/computers
Consumer Electronics	www.ti.com/consumer-apps
Energy and Lighting	www.ti.com/energy
Industrial	www.ti.com/industrial
Medical	www.ti.com/medical
Security	www.ti.com/security
Space, Avionics and Defense	www.ti.com/space-avionics-defense
Video and Imaging	www.ti.com/video

TI E2E Community

e2e.ti.com